

Electronic Control Catalog

Copyright SOMFY SYSTEMS, INC.

All rights reserved. No part of this catalog may be reproduced in any manner, stored in a retrieval system, or transmitted in any form, or by any means, electronic, mechanical, photocopying or otherwise without the prior written permission of SOMFY SYSTEMS, INC.

Printed in U.S.A. Revision 5/04

somfy[®]



MOTORIZATION CONCEPTS	2
GUIDELINES FOR SELECTING SOMFY SYSTEMS	2
ELECTRONIC PRODUCTS	
AC Motor Control	3
DC Motor Control	5
INTERFACING AND INTEGRATING	6

SWITCHES	7
TYPICAL AC WIRING DIAGRAM	8
DECORATOR SWITCH LINE	9
OUTDOOR PLUG-IN SYSTEM	10
DIGITAL KEYPAD	11
KEY SWITCHES	12
DECORATOR IGC SWITCH	13
DECORATOR RTS WIRELESS SWITCH	15
CHRONIS RTS TIMER	16
INTELLIS 24 HOUR TIMER	17
INFRARED SWITCH	19



INDIVIDUAL AND GROUP CONTROLS	21
INDIVIDUAL-GROUP CONTROL FOR DC MOTORS (IGC-DC)	22
DC-5 CONTROL	24
GROUP CONTROL SYSTEM II (GCS II)	26
INDIVIDUAL-GROUP CONTROL (IGC and IGC/3N1)	28
INDIVIDUAL-GROUP CONTROL II (IGC II and IGC II/3N1)	31
IGC SUB-GROUP CONTROL	34
MODULE SYSTEM	35



SUN AND WIND CONTROLS

37

DECORATOR SOMFY-MATIC™ (DSM)	38
DECORATOR COMFORT CONTROL (DCC)	40
EOLIS WIND CONTROL	42
EOLIS RTS RECEIVER	43
SOLIRIS RTS RECEIVER	45
TELIS SOLIRIS RTS TRANSMITTER	47
EOLIS & SOLIRIS RTS 24V SENSORS	48



REMOTE CONTROLS

49

CENTRALIS	50
RTS25-DC	52
TELIS RTS TRANSMITTERS	53
MULTILINK™	54
IRS 300 INFRARED CONTROL FOR DC MOTORS	56
SINGLE MOTOR REMOTE	58



ACCESSORIES AND SPECIAL APPLICATIONS

RS 232 INTERFACE MODULES	62
DRY CONTACT TO RTS INTERFACE	64
ISOLATION CONTROL	65
SYNCHRONIZING CONTROL	66
FABRIC TENSION SYSTEM (FTS) CONTROL	68
LT28 STALL SENSOR	69
ILT MOTOR CONTROLS	70
LON CONTROLS	72
ACCESSORIES	74

DC Transformers, Drapery Motor Controls, Motor Tester Cable, Modular Cable, IGC Tester Cable, Electrical Boxes





COMMITMENT



SOMFY is the world's largest manufacturer of tubular motors. For over 30 years, engineers at SOMFY have been designing motors and controls for the retractable awning, rolling shutter, interior window treatment, projection screen and other markets with a commitment to providing the highest level of quality and safety in the industry. Today our motor controls are rigorously tested both here in the U.S. and at our World Headquarters in Cluses, France, where Underwriters Laboratories has certified SOMFY's test facility. Underwriters Laboratories, or UL, is an independent, non-profit organization in the United States with the sole purpose of evaluating the safety of electrical products. SOMFY's selection as a UL Client Test Facility is further evidence of our dedication to providing the finest products on the market. SOMFY SYSTEMS, based in Cranbury, N.J. offers standard or customized electronic controls for the North American Market.

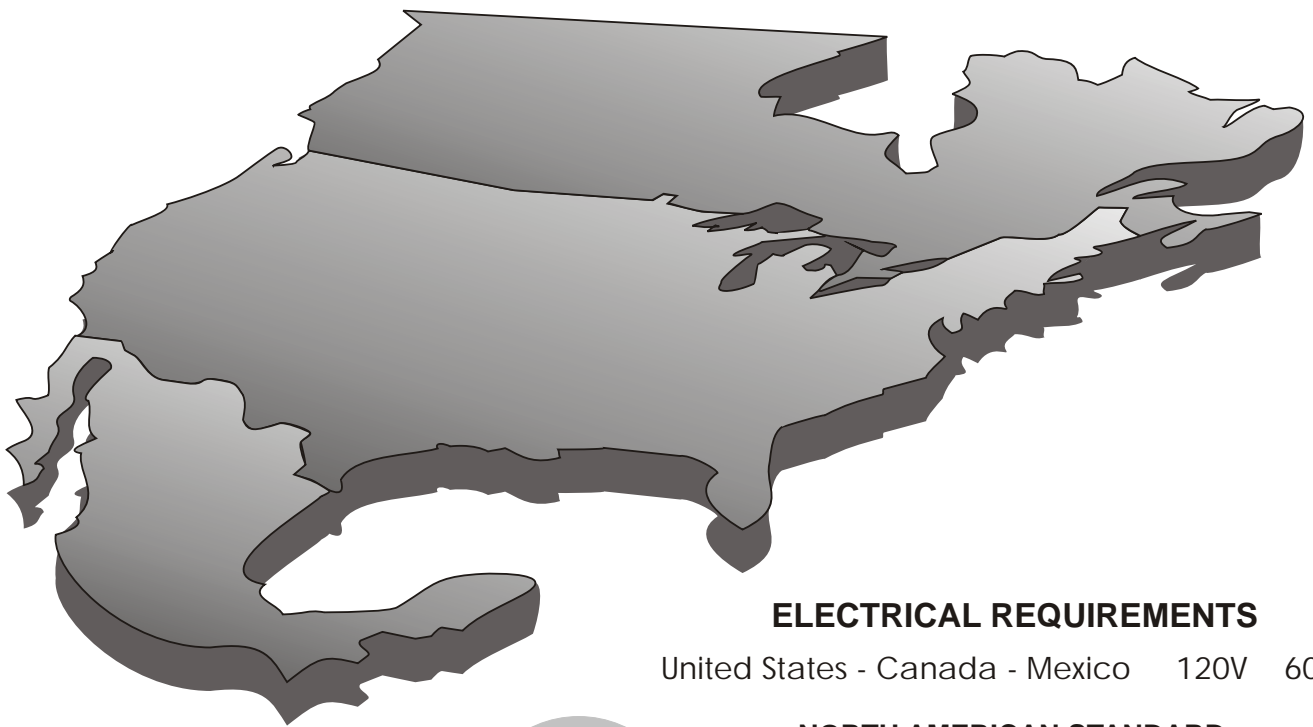

ELECTRICAL REQUIREMENTS

United States - Canada - Mexico 120V 60 Hz

NORTH AMERICAN STANDARD

SOMFY UL approved controls can be found in UL File No. E160923



Notice: In an ongoing effort to be the leader in our industry, motor controls are occasionally subject to modification or discontinuation. SOMFY SYSTEMS reserves the right to change, update, or improve this document without prior notice.



Guidelines for Selecting SOMFY SYSTEMS Electronic Products

Installations of dual direction motors require flexibility of control and compatibility not only with decor, but also with security, lighting, and environmental control systems. All SOMFY SYSTEMS control products are designed to maximize utility and aesthetics, as you will see in the catalog pages that follow. This section will help in selecting the devices that fit your application best by explaining the general options in a motor control system.

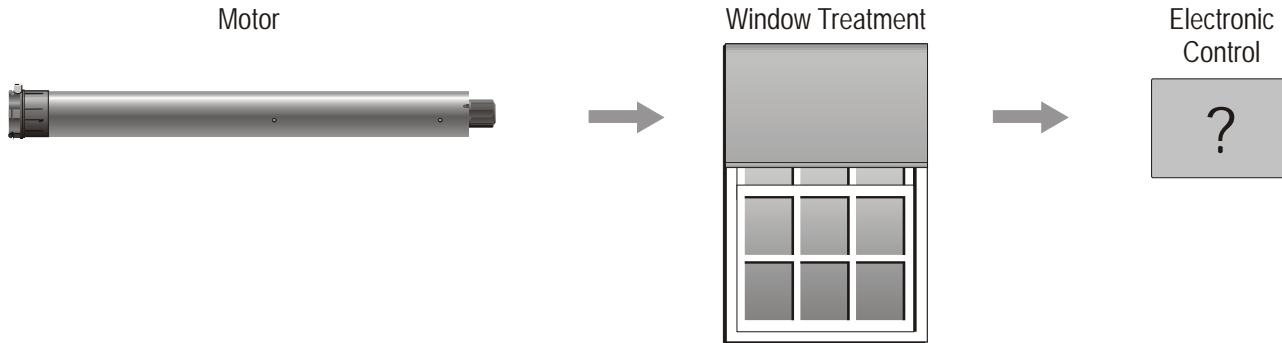

Why Do I need Motor Controls?

The design characteristics of an AC dual direction tubular motor which enables it to generate enough torque to raise awnings, shutters or shades, require several considerations in the design of its control circuit. First, these motors cannot be wired in parallel from a single switch as lighting fixtures can. There must be a SOMFY control device which prevents electrical feedback through the motor capacitor, such as a Group Controller or a network of Individual-Group controls. Second, one SOMFY motor cannot be controlled from several locations (switches) without a control device to build priorities among switch signals. A SOMFY Isolation Control or an Individual-Group Control (IGC) would apply here.

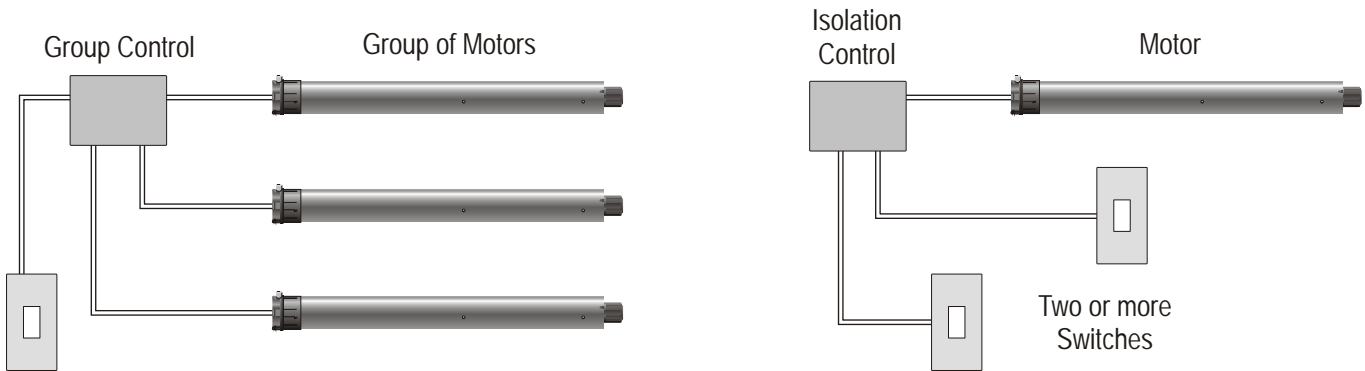

What is 'low voltage control' or 'low voltage input'?

Low voltage control refers to switch and automatic control inputs which interface with 120 volt AC motor controls. Low voltage (usually 12 volts DC) provided by the motor controller supplies the switches and allows for a more flexible system design than can be found with a 120 VAC or 'line voltage' switch network. Low voltage wiring eliminates some of the hazards of line voltage, and is accomplished safely with inexpensive low voltage rated wire or modular cable.

DC motors, by definition, include low voltage controls. The wiring requirements for DC motors are different than described above, and will be discussed later in this section.

MOTORIZATION CONCEPTS (Cont'd)

Switches

Switches are the most common interface between the user and the motor or motor controller.

SOMFY offers a line of elegant switches made exclusively for motor control. These switches feature up, down, and stop positions in both momentary and maintained configurations for hardwired AC control of a single motor. Momentary switches will continue to drive the motor in a given direction as long as that switch direction is depressed, or until the motor reaches its limit in that direction.

Maintained switches can be pressed and released and the motor will travel to its limit in the chosen direction. If you are required to control a single motor from two or more locations, it will be necessary to have all the switches interface with a SOMFY Isolation Control unit. If one switch is required to control two or more motors, you will need to review the Group Control products.

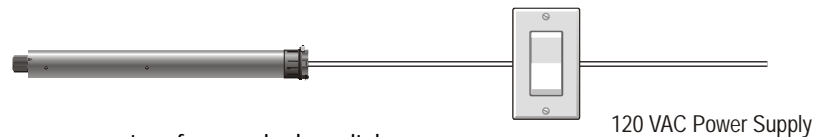

Group Control

Group Control is the movement of 2 or more motors from a single switch.

The SOMFY Group Control System allows for simultaneous control of an unlimited number of motors. At the heart of the Group Control System is the GCS-II which controls up to 4 motors as a group. The GCS-II accepts low voltage inputs from SOMFY's own line of switches and it can be activated by building lighting or automation systems. In addition, SOMFY offers sun and wind controls for the GCS-II as well as a radio remote control option. Multiple GCS-II's can be linked together and operated by a single "master" switch. If, however, both group control and individual control of a number of motors is necessary, SOMFY offers a line of Individual-Group Control products.

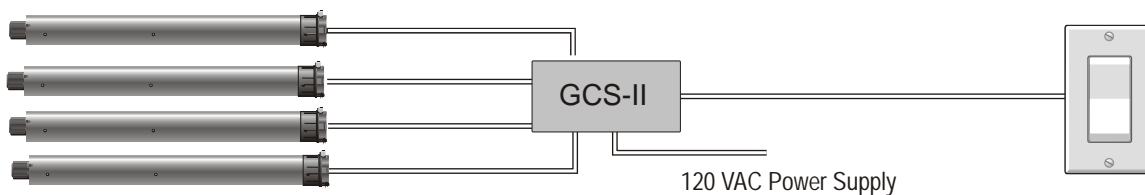

Individual-Group Control

Individual-Group Control includes all the functionality of Group Control (above) while maintaining the ability to operate each motor individually or in smaller 'sub-groups'.

Under ideal conditions, you would be able to control each of a number of motors individually but also maintain the capability to operate them as a group. SOMFY IGC products make this possible. The IGC is a single motor controller with low voltage individual and group switch inputs. Control options include switches, timers, remotes, lighting controls, and sun and wind control. To gain economies of scale, install the IGC/3N1. The 3N1 is a 3 motor controller with individual inputs for each of the 3 motors and a master switch input to operate all 3 at once. Any number of IGCs and IGC/3N1s can be linked to achieve the ultimate in flexible systems. If remote control is specified, SOMFY offers the IR (Infrared) Switch, which combines the elegance of the IGC switch with the convenience of infrared remote control in a single gang box. In addition, the IGC II and IGC II/3N1 add infrared remote capabilities through an X10 interface.

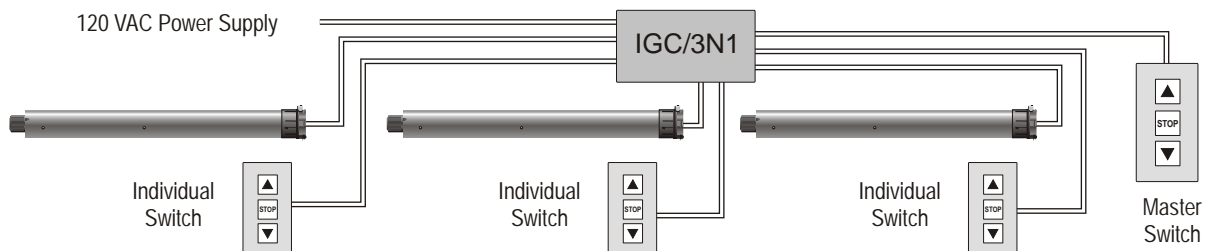

Remote Control

Remote Control enhances comfort and convenience, and is GCS and IGC compatible.

To satisfy today's consumers' need for comfort and convenience, SOMFY SYSTEMS offers a complete line of remote control products in both infrared and radio frequencies. Infrared controls are typically less expensive but require the user to be indoors and in line of sight of the infrared receiver. Radio remote control provides a greater range and the signal can be transmitted through walls and floors, so receivers can be mounted out of sight. In both cases, remote control not only adds functionality, but by eliminating wall switches it also relieves some of the wiring burden during installation. Remote control units can be stand-alone for one to three motors, or they can be interfaced with group or individual controls. There is a SOMFY remote control solution for every motor or group application.

Somfy's newest innovation in Remote Control is Radio Technology Somfy™(RTS), where the radio receiver is built right in the motor.

MOTORIZATION CONCEPTS (Cont'd)

Remote Control

To satisfy today's consumers' need for comfort and convenience, SOMFY SYSTEMS offers a complete line of remote control products in both infrared and radio frequencies. Infrared controls are typically less expensive but require the user to be indoors and in line of sight of the infrared receiver. Radio remote control provides a greater range and the signal can be transmitted through walls and floors, so receivers can be mounted out of sight. In both cases, remote control not only adds functionality, but by eliminating wall switches it also relieves some of the wiring burden during installation. Remote control units can be stand-alone for one to three motors, or they can be interfaced with group or individual controls. There is a SOMFY remote control solution for every motor or group application.

Somfy's newest innovation in Remote Control is Radio Technology Somfy™ (RTS), where the radio receiver is built right in the motor. Wiring is minimized during installation, as only power to the motor is required. With the Inteo line of controls, standard LT motors can be controlled side by side with RTS Motors, using the Telis Transmitters.

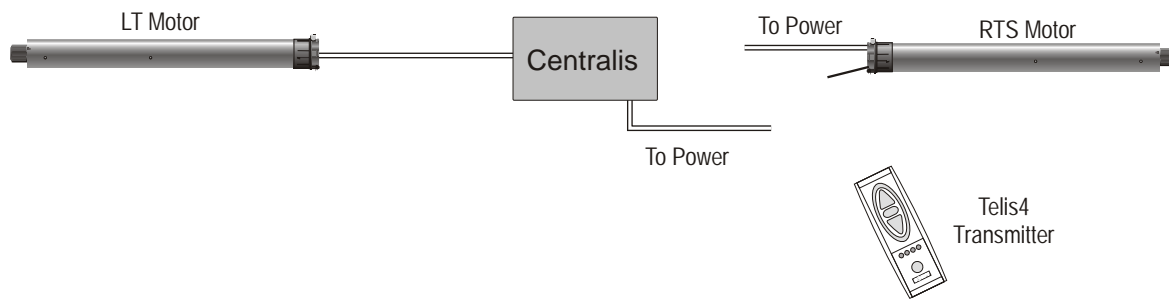

Automatic Controls

Motors can be controlled automatically based on the sun, wind, or time of day.

The ultimate motor control is a SOMFY SYSTEMS automatic controller. Based on the intensity of the sun, the wind, or just the time of day, intelligent environmental controls and timers can position a single motor or a whole house full even when there's no one home. These controls are engineered to be compatible with the entire line of SOMFY products, and can be integrated into a system with manual switch stations and remote control. Automatic controls are available with standard installation features or in an outdoor plug-in system, reducing the wiring requirements for outdoor (awning) applications.

For standard LT motors, use the Decorator Somfy-Matic™ (DSM) for sun and wind control; the Decorator Comfort Control (DCC) for protection from the sun only; the Eolis Box for wind protection only; and the Intellis Timer for time of day control. If radio remote operation is desired, the Soliris or Eolis Receiver RTS will provide automation based on sun and wind conditions. For the most streamlined installation, however, an RTS motor can be paired with a Soliris or Eolis 24v RTS Sensor. These sensors wirelessly transmit commands to the motor to raise or lower based on the sun or wind conditions. The Chronis Timer will operate RTS motors or Inteo Controls if wireless time of day operation is desired.

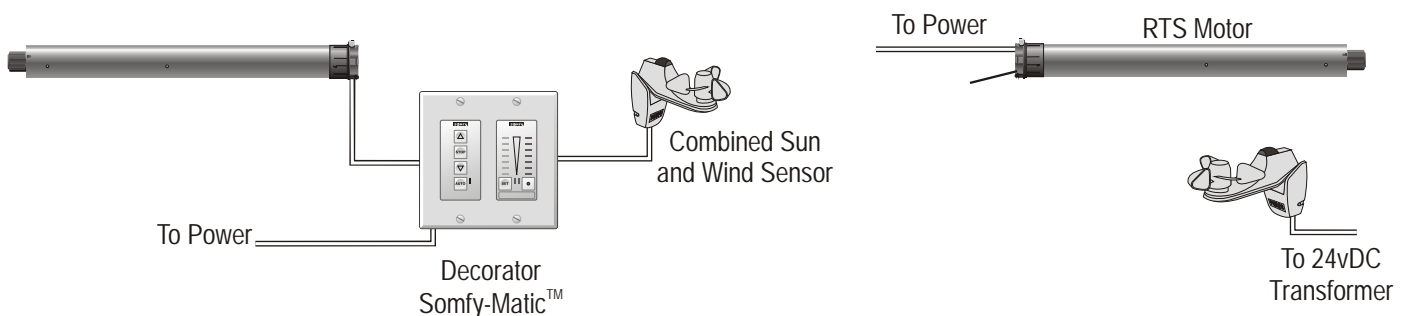

MOTORIZATION CONCEPTS (Cont'd)

DC MOTOR CONTROLS

The use of DC motors eliminates some of the complexities required for controlling AC motors. SOMFY SYSTEMS line of DC motor controls includes Switches, Individual-Group Controls, and Infrared Remote Controls. Keep in mind that whenever DC motors are called for, a transformer must be specified to supply power to the system.

Switches

DC motors can be wired in parallel from a single switch. One or more motors can be controlled from a single low voltage switch. SOMFY's switches feature momentary or maintained operation, and are offered in rocker and toggle styles.

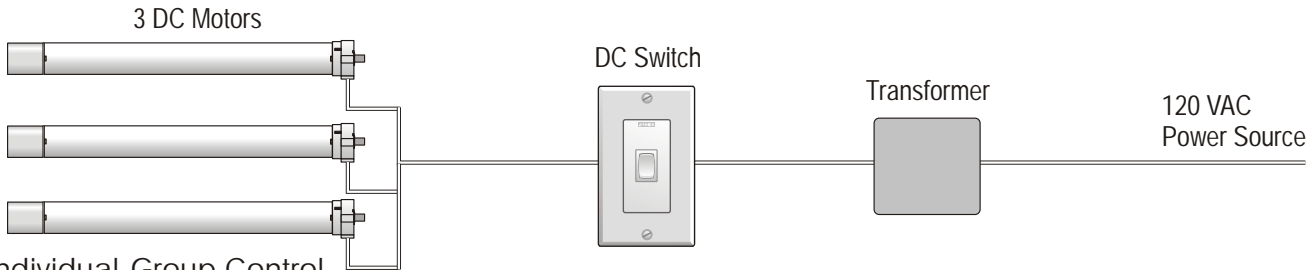

Individual-Group Control

While a simple switch can control a small group of DC motors, the DC5 is necessary for preserving both individual and group control. Each DC5 Control operates up to five motors Individually using a push-button switch or infrared control. A Master Switch connection is available for Group Control and for connecting to other DC5 controls.

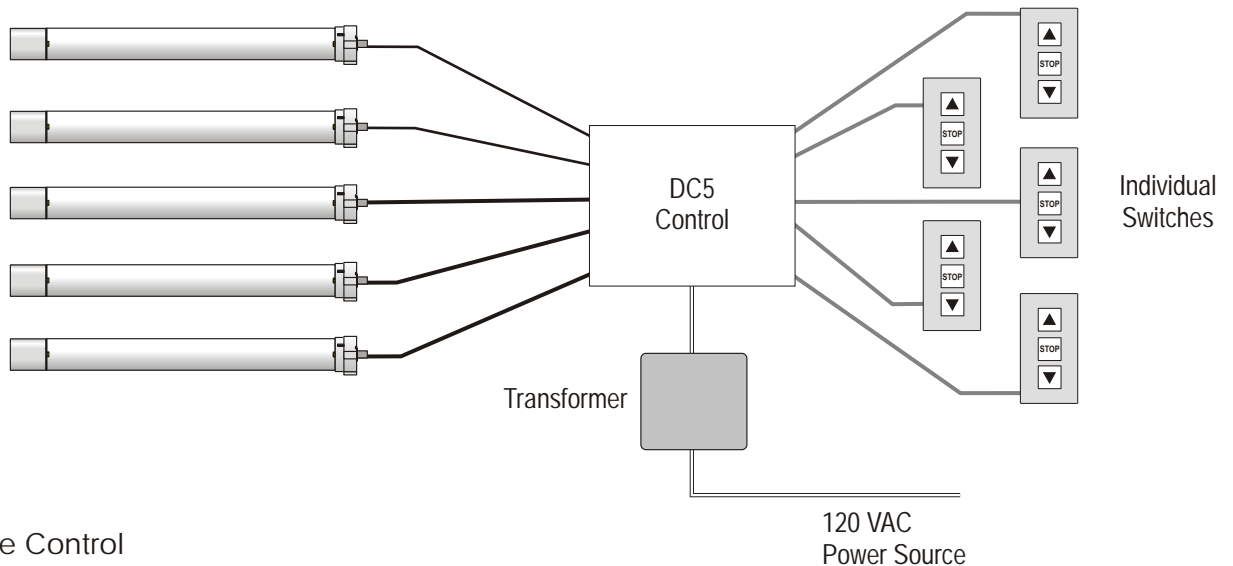

Radio Remote Control

Radio control provides a convenient method of operating DC motors. With the RTS25 DC, up to 3 motors can be controlled simultaneously from a single Telis Transmitter. The RTS25 can be programmed with tilt, an intermediate position, and varying speeds. It can be mounted in the headrail with the motor, or externally.

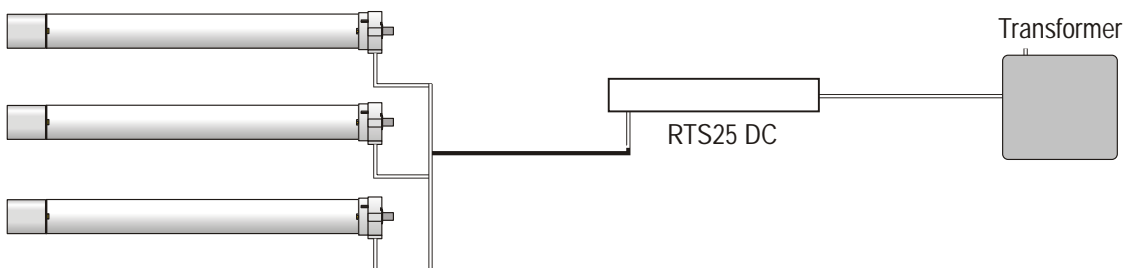

MOTORIZATION CONCEPTS (Cont'd)

INTERFACING and INTEGRATING

In today's world of increasing technology, we are automating our lifestyles more and more to save time and gain convenience. SOMFY is committed to providing the best products and service to systems integrators. Most of SOMFY'S controls have low voltage interface points for control by outside home automation or lighting systems. These details are located throughout the catalog pages.

SOMFY SYSTEMS also has an RS232 module that will communicate between a PC and SOMFY controls. For more complex systems, SOMFY offers a line of LON compatible controls that operate with our ILT motor. This system has the ability, through software, to monitor outside light conditions in order to optimize indoor lighting and temperature.

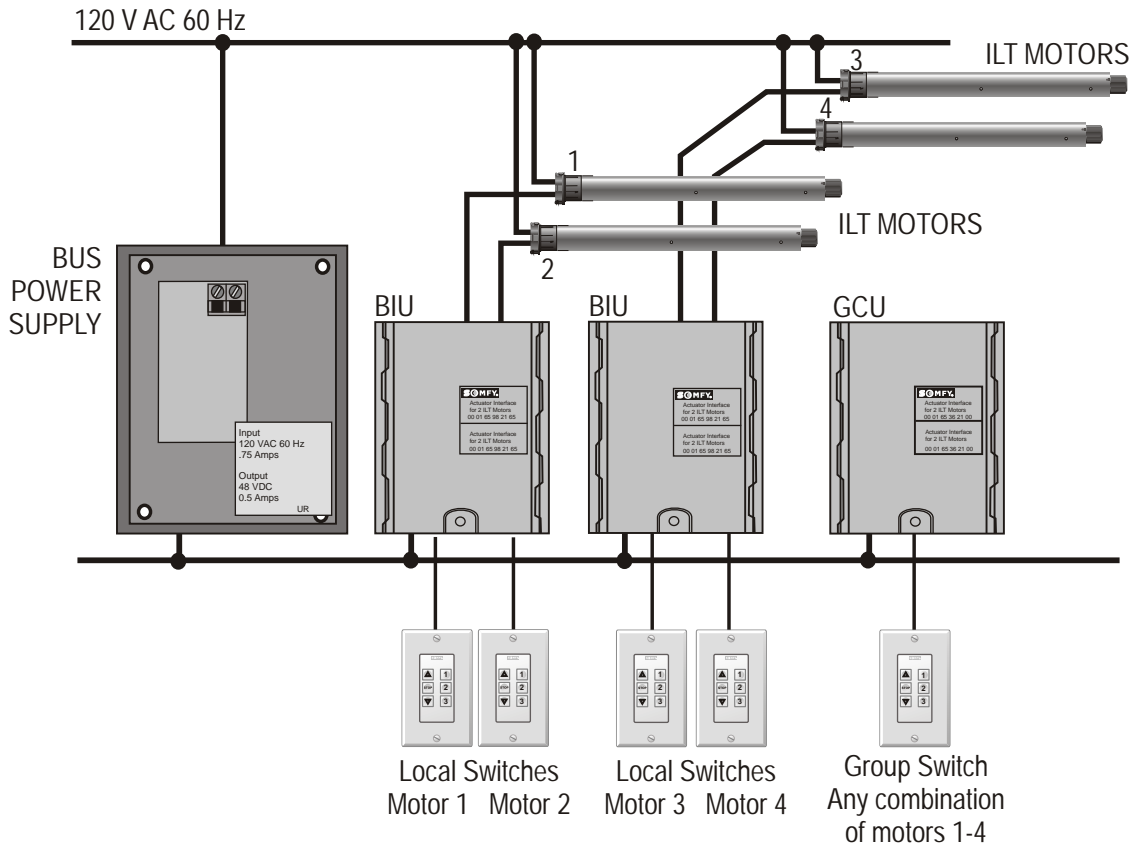
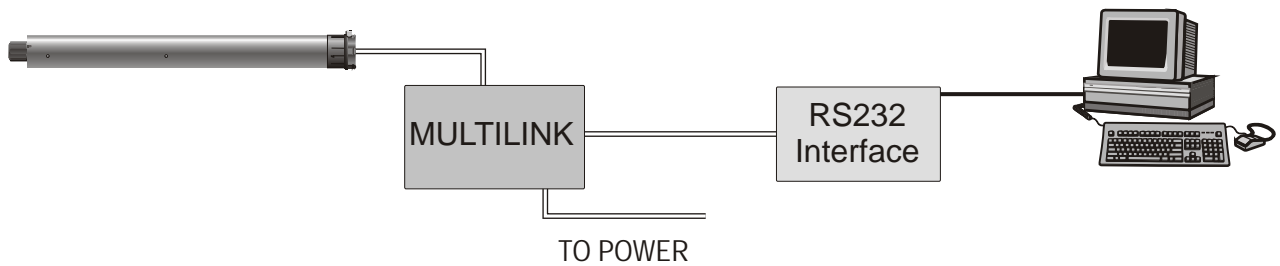



Decorator Switches

9

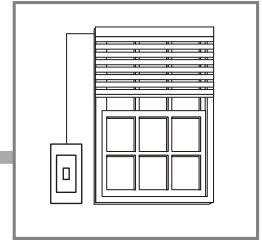

Outdoor Plug-in System

10

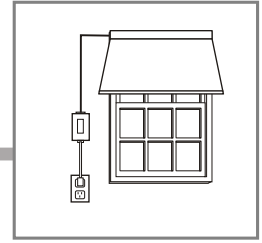

Digital Keypad

11

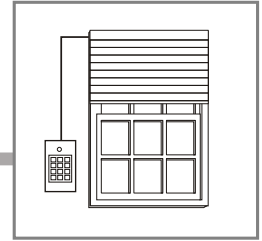

Key Switches

12

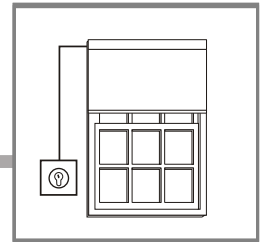

Decorator IGC Switches

13

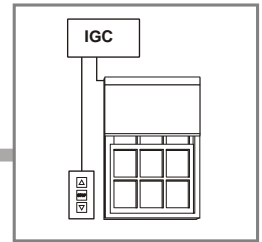

Decorator RTS Switch
Chronis RTS Timer

15

16

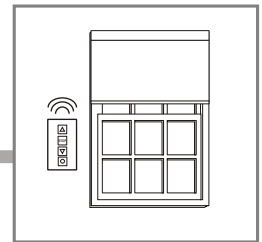

Intellis Timer
Infrared Switch

17

19

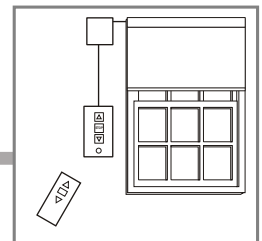

DECORATOR SWITCH LINE

DESCRIPTION

SOMFY's Decorator Switches provide easy control of all types of motorized window applications. Their rugged yet elegant design complement any decor. They are available in white and ivory and, with the exception of the standard DC Switches, feature a maintained or momentary model.

NOTE: Switchplates must be ordered separately



APPLICATIONS

ONE MOTOR / SINGLE POLE SWITCH

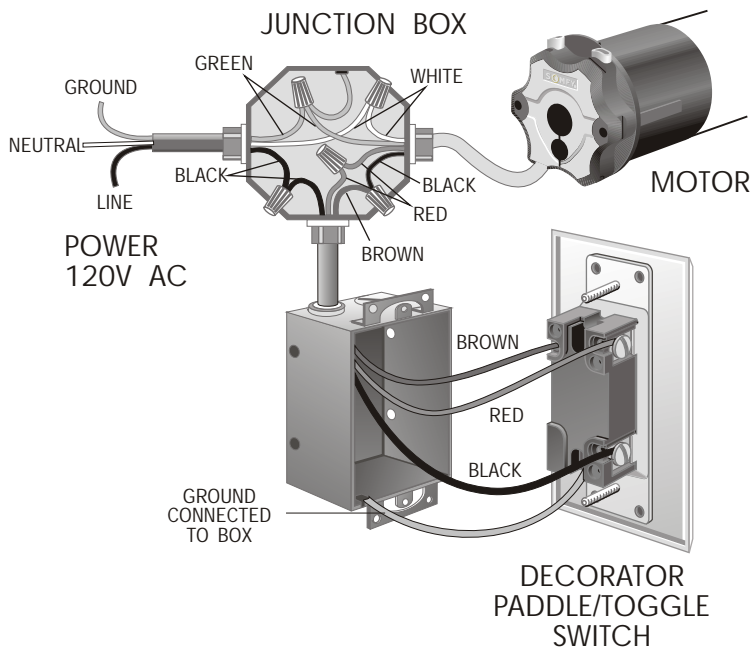

TWO MOTORS / DOUBLE POLE SWITCH

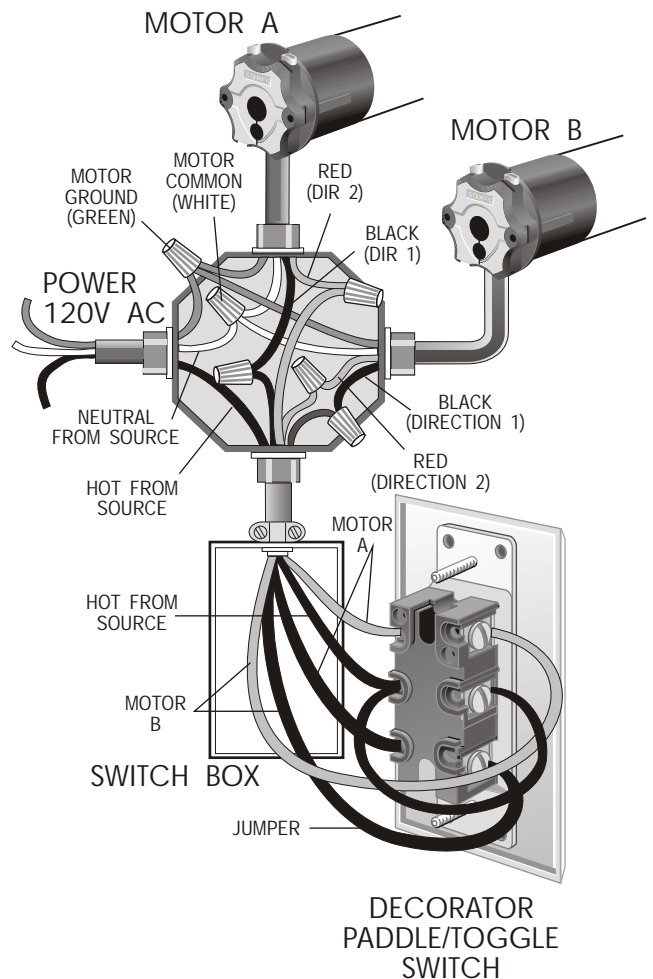

CAUTION: Before proceeding with the line voltage wiring instructions, the up and down limits of each motor should be set using the SOMFY tester cable (Cat. No. 6020086). Refer to the limit switch instructions packaged with each SOMFY motor for more information.

DC DECORATOR ROCKER SWITCHES

The DC Decorator switch line is designed for DC motorized interior window treatment applications. Both single and double switch stations are single pole, double throw, with center off. The soft contours and coloring of the switches will complement any decor, and they are designed to fit into a standard single gang electrical box.

Description	Catalog Number
DC Rocker Switch (Maintained - Single)	6300922
DC Rocker Switch (Maintained - Double)	6300923
DC Rocker Switch (Momentary - Single)	6300967
DC Rocker Switch (Momentary - Double)	6300968



Cat. No. 6300922



Cat. No. 6300923

STANDARD DC SWITCHES

SOMFY's three-position maintained DC toggle and rocker switches provide convenient fingertip control of any DC controlled window treatment in your installation. These switches feature up, down, and center stop positions, and are the maintained type. They mount easily into a standard single gang box.

Description	Catalog Number
DC Rocker Switch (White)	6120694
DC Rocker Switch (Ivory)	6120695



Cat. No. 6120694

5 POSITION DC SWITCHES

SOMFY's five position DC switches are designed to give both maintained and momentary outputs. This is especially useful for tilt control with horizontal blinds. These switches are designed to mount in a single gang electrical box.

Description	Catalog Number
5 Position 2 Speed DC Rocker Switch	6120742
5 Position DC Rocker Switch	6300951



Cat. No. 6120742



Cat. No. 6300951

DECORATOR AC SWITCHES

SOMFY'S AC switches are designed for window treatments using SOMFY'S AC motor line. The 5 position switches offer both momentary and maintained outputs, with center off. This is especially useful for tilt control with horizontal blinds. These switches mount in a single gang electrical box.

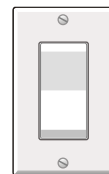

Cat. No. 6120727



Cat. No. 6120746

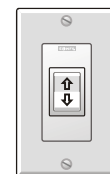

Cat. No. 6300924

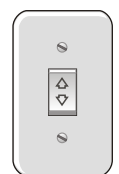

Cat. No. 6120144

Description	Catalog	Description	Catalog
5 Position AC Decorator Rocker Switch	6300924	Rocker Switch Kit w/Princess Plate (Maintained - Ivory)	6120144
Decorators Paddle Switch (Maintained - Ivory)	6120726	Rocker Switch Kit w/Princess Plate (Maintained - White)	6120688
Decorators Paddle Switch (Maintained - White)	6120727	Rocker Switch Kit w/Princess Plate (Momentary - Ivory)	6120155
Decorators Paddle Switch (Momentary - Ivory)	6120734	Rocker Switch Kit w/Princess Plate (Momentary - White)	6120689
Decorators Paddle Switch (Momentary - White)	6120735	Rocker Switch Kit w/Standard Plate (Maintained - Ivory)	6120403
Decorators DPDT Paddle Switch (Maintained - White)	6120728	Rocker Switch Kit w/Standard Plate (Maintained - White)	6120404
Decorators DPDT Paddle Switch (Maintained - Ivory)	6120729	Rocker Switch Kit w/Standard Plate (Momentary - Ivory)	6120414
Decorators Toggle Switch (Maintained - Ivory)	6120745	Rocker Switch Kit w/Standard Plate (Momentary - White)	6120415
Decorators Toggle Switch (Maintained - White)	6120746	Rocker Switch Kit w/Alum. Std. Plate (Maintained - White)	6120405
Decorators Toggle Switch (Momentary - Ivory)	6120747	Rocker Switch Kit w/Alum. Std. Plate (Momentary - White)	6120416
Decorators Toggle Switch (Momentary - White)	6120748		

OUTDOOR PLUG-IN SYSTEM

DESCRIPTION

The Outdoor Plug-in System enables a dealer to install a motorized retractable awning and adjust the limit switches in just one visit! The motor cable plugs directly into the prewired control switch and the detachable power cable plugs into an outdoor receptacle. Custom fit male/female connectors make installation simple.

The system's quick and easy disconnect feature provides the customer with additional safety and security. The end user can easily disconnect it during the winter months, or to prevent tampering while the premises are vacant.



MECHANICAL SPECIFICATIONS

Overall Dimensions: L: 5 ³/₄ in. W: 2 ¹/₂ in. D: 3 in.

Switch comes installed in an outdoor weatherproof box.

APPLICATION

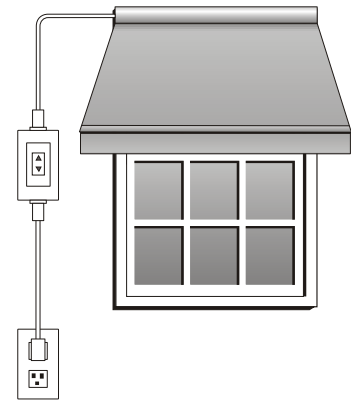

ORDERING INFORMATION

Description	Catalog Number
Plug-in Maintained Switch	6180291
Plug-in Momentary Switch	6180292
6 Ft. Plug-in Power Cord	6020387
6 Ft. Plug-in Motor Cable Extension (Optional)	6020391
6 Ft. Plug-in Power Cord Extension (Optional)	6020396
6 Ft. Plug-in Standard LT Motor Cable	6020505
6 Ft. Plug-in LT CMO Motor Cable	6020515
6 Ft. Plug-in Cable installed on LT motors	6180295
6 Ft. Plug-in Cable Installed on LT CMO	6180296

NOTE: Specify Motor Type When Ordering This System

DIGITAL KEYPAD

DESCRIPTION

The Somfy Digital Keypad is a programmable indoor or outdoor security switch for rolling shutters, doors and grilles. SOMFY's easy to install and simple to use Digital Keypad is the perfect "KEYLESS" solution and a convenient control for motorized rolling shutters and grilles. Designed for security conscious customers, the Digital Keypad features a personal code number to help prevent unwarranted access to their premises. The private entry code can be changed by the end user to ensure limited access or protection should a compromise of security occur.



OPERATING AND PROGRAMMING INSTRUCTIONS

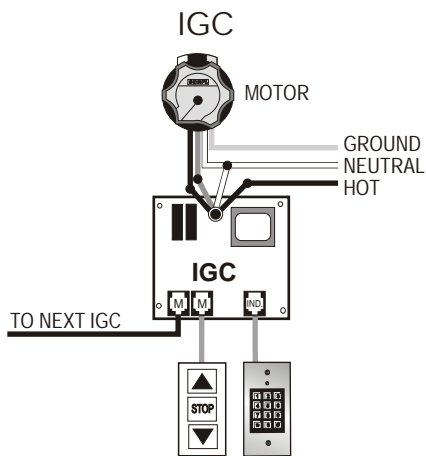

The IGC Outdoor Digital Keypad comes factory programmed with codes for UP, DOWN, and STOP. When the UP code is entered, the keypad will command the IGC to raise the shutter or grille. Similarly, the shutter or grille will lower when the DOWN code is entered.

To keep secure access, the codes can be reprogrammed by following these steps:

KEYPAD ENTRY	FUNCTION
*382436#	Enter programming mode
*193#	Set code length to 3 digits
*11UUU#3#	UUU is the UP code (enter desired digits)
*11SSS#34#	SSS is the STOP code
*11DDD#4#	DDD is the DOWN code
*2301#	Set output pulse width
*2401#	
*99#	Exit programming mode

SINGLE MOTOR REMOTE

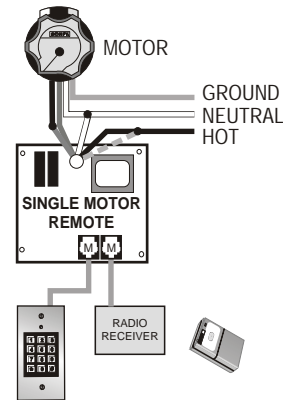

The Digital Keypad for Remote Control comes programmed with a single security code. Every time the code is entered, the Remote Control will sequence through UP, STOP, DOWN, STOP.

Follow these steps to change the security code:

1. Locate the code bank on the decoder module. It has 17 socket positions (*, 0, 1, 2, 3, 4, 5, 6, 7, 8, 9, #) which are printed on the circuit board.
2. Socket positions A B C D E represent the five possible digits of the operating code. Socket position A is the first digit, while E is the last digit of the code.
3. Place one end of a program jumper wire (pre-installed) in socket A and the other end in the desired first digit. Repeat this process for B, C, D, and E. NOTE: You may not use the same number twice in the operating code.
4. Attach the decoder to the keypad. Locate the 13 position socket marked S2 on the decoder board. Align socket S2 with the 13 positions on the keyboard and carefully press the socket onto the pins.

ORDERING INFORMATION

Description	Catalog Number	Description	Catalog Number
Outdoor Digital Key Pad for IGC	6300849	Indoor Digital Key Pad for Remote Control	6300739
IGC Controller	6300717	Outdoor Digital Key Pad for Remote Control	6300740
2 Gang Electrical Box	5670323	Remote Controller	6300690

KEY SWITCHES

DESCRIPTION

SOMFY's line of high-security outdoor Key Switches are protected by a tamper proof cover that cannot be removed without inserting the key. They are available with flush or surface mounting and maintained or momentary switching.

SOMFY also offers several indoor Key Switches for those areas that require enhanced security. These Key Switches include heavy duty and light duty models with either momentary or maintained operation.



WIRING DIAGRAM

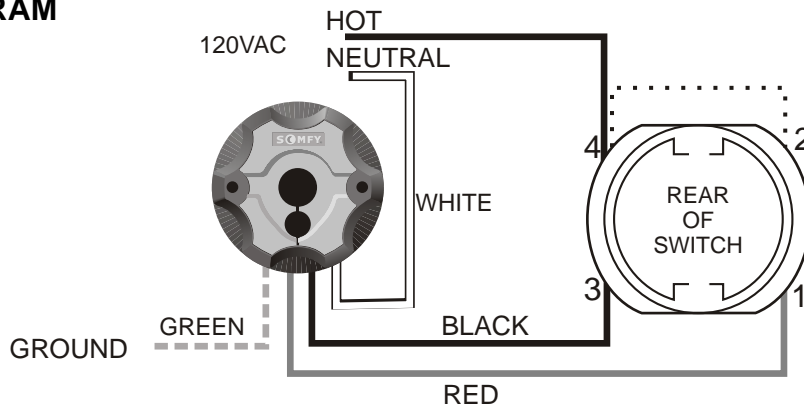

ORDERING INFORMATION

Outdoor Key Switches

Heavy Duty Momentary Outdoor Key Switch (surface mount)
Heavy Duty Momentary Outdoor Key Switch (flush mount)
Heavy Duty Maintained Outdoor Key Switch (surface mount)
Heavy Duty Maintained Outdoor Key Switch (flush mount)
Key Blanks for Outdoor Key Switches
Rain Hoods for Outdoor Key Switches
Keyed Alike Key Switch Cylinder

Catalog Number

6120212
6120622
6120223
6120623
6110761
6110774
6110772

Note: Upon special request, Key Switches can be keyed alike.

Indoor Key Switches

Heavy Duty Momentary Indoor Key Switch
Heavy Duty Maintained Indoor Key Switch
Light Duty Momentary Indoor Key Switch
DP/DT Momentary Indoor Key Switch
DP/DT Maintained Indoor Key Switch
Key for Heavy Duty Indoor Switch
Key for Light Duty Momentary Indoor Switch

6120201
6120199
6120234
6120582
6120593
6110425
6110293

DECORATOR IGC SWITCH

DESCRIPTION

The Decorator IGC switch line is designed for use with SOMFY's IGC and IGC/3N1 controls. This switch features a 6 pin modular connector which takes advantage of modular cable to connect it to a motor controller. The IGC Switch can be used for individual or group control. Both single and double switch stations come in white and ivory, and feature UP, STOP and DOWN buttons. The soft contours and neutral colors complement any decor.



MECHANICAL SPECIFICATIONS

Overall Dimensions: L: 4 1/2 in. W: 2 3/4 in. D: 1 1/2 in.

Installs in a standard single gang electrical box.

The Decorator IGC Switches are compatible with these SOMFY

DC5	Cat. No. 6300370
IGC	Cat. No. 6300717
IGC/3N1	Cat. No. 6300719
IGC II	Cat. No. 6300817
IGC/3N1 II	Cat. No. 6300819
IGC-DC	Cat. No. 6300843
Synchronizing Control	Cat. No. 6300889
Eolis Wind Control	Cat. No. 6301021
MultiLink	Cat. No. 6301991

CONNECTION DIAGRAM

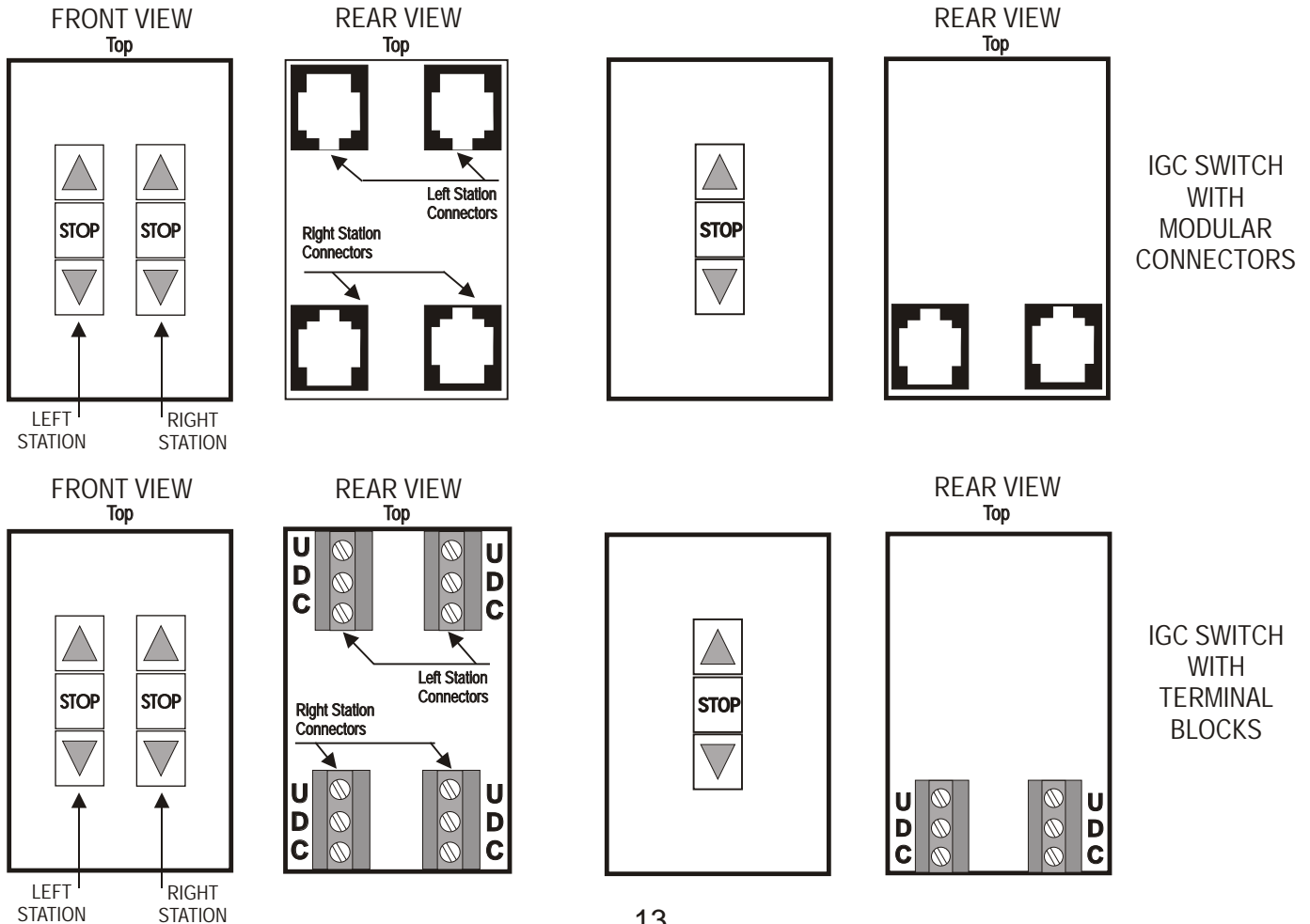

APPLICATION

Below is an illustration of how the Decorator IGC switches are used in conjunction with the SOMFY IGC, IGC/3N1 and the IGC Sub-Group Control to create individual motor, group motor, floor control and master (entire house) control.

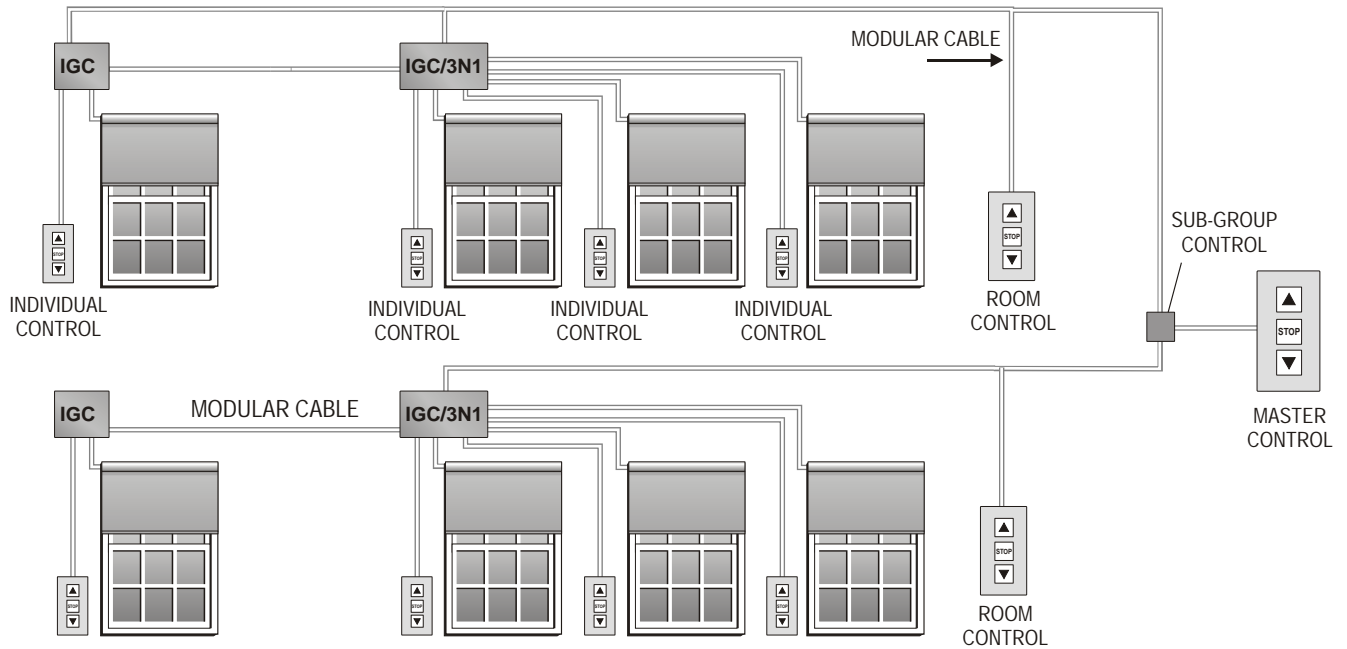

MODULAR CABLE DETAILS

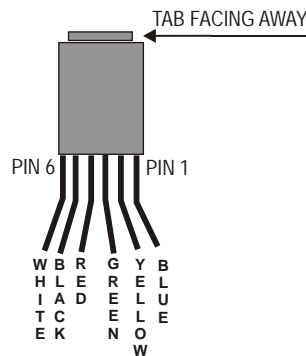
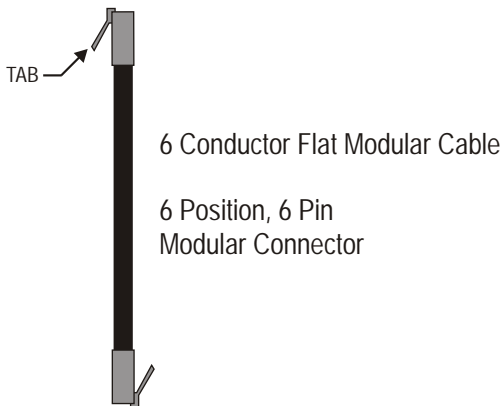

COLOR	PIN NO.	FUNCTION
WHITE	6	UP
BLACK	5	DOWN
RED	4	+12 VDC
GREEN	3	COMMON
YELLOW	2	NOT USED
BLUE	1	NOT USED

ORDERING INFORMATION

Description	Catalog Number	Description	Catalog Number
Single IGC Switch (White)		Single IGC Switch with Terminals (White)	
Single IGC Switch (Ivory)	6300908	Single IGC Switch with Terminals (Ivory)	6300040
Dual IGC Switch (White)	6300937	Dual IGC Switch with Terminals (White)	6300140
Dual IGC Switch (Ivory)	6300909	Dual IGC Switch with Terminals (Ivory)	6300041
	6300938		6300141

DECORATOR RTS WIRELESS SWITCH

DESCRIPTION

The Decorator RTS Switch (single or four channel) is a wireless radio switch compatible with all the RTS Motors, and externally mounted RTS receivers. It will operate window coverings at a distance with no wiring between the switch and motor or receiver. Commands are transmitted by radio waves at 433.42 MHz.



MECHANICAL SPECIFICATIONS

Overall Dimensions: L: 4 1/2 in. W: 2 3/4 in. D: 1 1/4 in.

Operating Temperature: 41°F to 104°F

Frequency Range (optimal conditions): 65 ft.

Installs in a standard, plastic, single gang electrical box.

ELECTRICAL SPECIFICATIONS

Power: 3V Lithium battery, Cr2430

Frequency: 433.42 Mhz

GENERAL OPERATING INSTRUCTIONS

NOTE: Please Consult RTS Motor or Receiver Instructions for Specific Product Details.

1. Place the RTS Motor or Receiver in Programming Mode as described in the Operating Instructions.
2. Press the programming button on the side of the RTS Switch to program it in the memory of the RTS Motor or Receiver. Be sure the channel is first selected on the four channel model.
3. Pressing the UP button will raise the window covering, while pressing the DOWN button will lower it. To stop the window covering, simply press the STOP button.
4. Pressing the Channel Selector button on the 4-Channel Switch will sequence through the channels. Each LED will light to indicate the channel selected. The Master or 5th channel is indicated when all LEDs are lit.

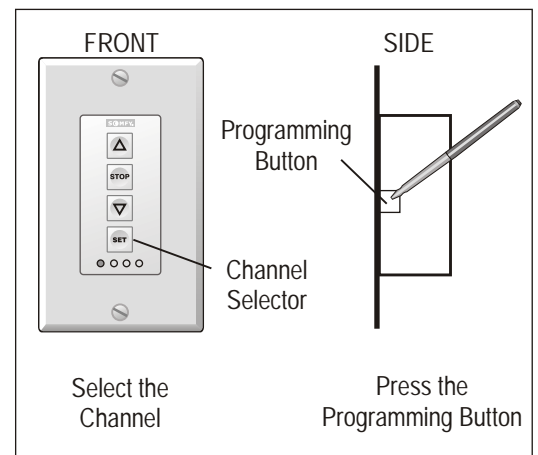

ORDERING INFORMATION

Description	Catalog Number	Description	Catalog Number
Single Channel RTS Switch - White	6301033	Four Channel RTS Switch - White	6301025
Single Channel RTS Switch - Ivory	6301034	Four Channel RTS Switch - Ivory	6301035

CHRONIS RTS TIMER

DESCRIPTION



SOMFY's new Chronis RTS Timer is a wireless digital timer compatible with all the RTS Motors and externally mounted RTS Receivers such as the Centralis. It will automatically raise and lower window treatments based on the pre-set time of day. The Chronis can be programmed to operate at the same time each day or different times every day. It has a security function that will raise or lower shades randomly to give the impression of an occupied home. The Chronis Lite has the addition of a light sensor, so window treatment automation can also be determined by external sun levels. Commands are transmitted via radio, so external wiring is not necessary.

MECHANICAL SPECIFICATIONS

Overall Dimensions: L: 3 1/8 in. W: 3 1/8 in. D: 1 in.

Operating Temperature: 41°F to 104°F

Frequency Range (optimal conditions): 65 ft.

ELECTRICAL SPECIFICATIONS

Power: 2 1.5V DC (AAA) batteries

Frequency: 433.42 Mhz

GENERAL OPERATING INSTRUCTIONS

NOTE: Please Consult RTS Motor or Receiver Instructions for Specific Product Details.

1. Place the RTS Motor or Receiver in Programming Mode as described in the appropriate Operating Instructions.
2. Press the programming button on the Chronis, "PROG" will appear in the display. Continue holding the programming button until the RTS Motor or Receiver confirms it is memorized.
3. Program the UP and DOWN times for each day of the week, according to the Chronis operating instructions. The Chronis will automatically raise or lower the window treatments at the set time.
4. For Chronis Lite installation, connect the suction cup sensor to the control and window. Enter the sun level as described in the Chronis Lite instructions. The shade will lower automatically when the sun level is exceeded.
5. To manually operate the shades, press the UP button to raise the window covering, or press the DOWN button to lower it. To stop the window covering, simply press the STOP button. Intermediate stop positioning (IP) can also be activated. See instruction manual for details.

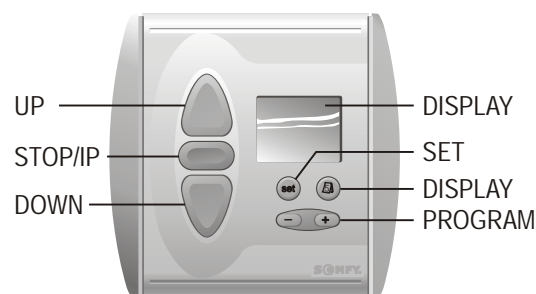

ORDERING INFORMATION

Description	Catalog Number
Chronis Timer	
Chronis Lite Timer with Sun Sensor and 6' Cord	6300383 6300385

INTELLIS 24 HOUR TIMER

DESCRIPTION

IntelliS is an easy-to-use timer for SOMFY motors. Each day, IntelliS will automatically raise or lower window treatments at a specified time. It is compatible with SOMFY's IGC and GCS-II controls to operate different combinations of individual and groups of window treatments. There is also a model that will operate a motor directly. With the included bracket, the IntelliS Single Motor easily mounts next to existing light switches. Programming is simple, with no confusing displays or rotary dials.

With just the push of a button, IntelliS is in control.



MECHANICAL SPECIFICATIONS

Overall Dimensions: L: 4 1/2 in. W: 2 3/4 in. D: 1 1/4 in.

Installs in a standard single gang electrical box.

ELECTRICAL SPECIFICATIONS

Voltage Rating:

Single Motor

Input 120 VAC +/- 10% 60 Hz
Output 120 VAC 5A 1/4 HP

IGC/GCS

Input 12-15 VDC 150 MA (supplied by IGC or GCS)
Output 12-15 VDC 150 MA (open collector)

Approvals: The IntelliS Single Motor is UL508 for industrial controls (UL, CUL) where applicable. Complies with the National Electrical Code (NEC) standard.

PROGRAMMING

IntelliS has two modes - Manual, and Automatic. In Manual Mode, the AUTO light is off and IntelliS functions like a standard SOMFY switch. In Automatic Mode the AUTO light is on, and IntelliS moves window treatments UP once each day and DOWN once each day, at the times you have chosen. To program the IntelliS, simply press the auto button and hold it for approximately 5 seconds, until the AUTO light begins to blink. Continue pressing the AUTO button, then press the button (UP or DOWN) corresponding to the direction you desire the window treatment to move. IntelliS memorizes the action, and will perform the same action at the same time every day. Later, at the time you wish the window treatment to move in the opposite direction, press and hold the auto button for 5 seconds until the AUTO light begins to blink, continue pressing the AUTO button then press the button for that direction. IntelliS is now fully programmed, and will repeat this cycle every 24 hours moving window treatments at the precise times you have programmed.

WIRING DIAGRAM

SINGLE MOTOR

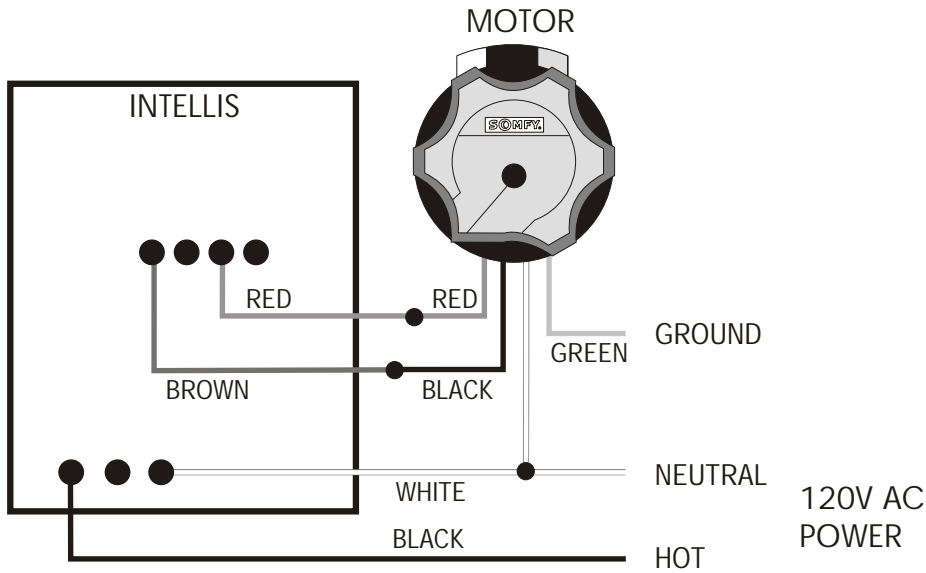

INTELLIS	MOTOR	POWER
RED	RED	
BROWN	BLACK	
	GREEN	GREEN
WHITE	WHITE	WHITE
BLACK		BLACK

Line Voltage installation **MUST** comply with local and NEC codes.

GCS

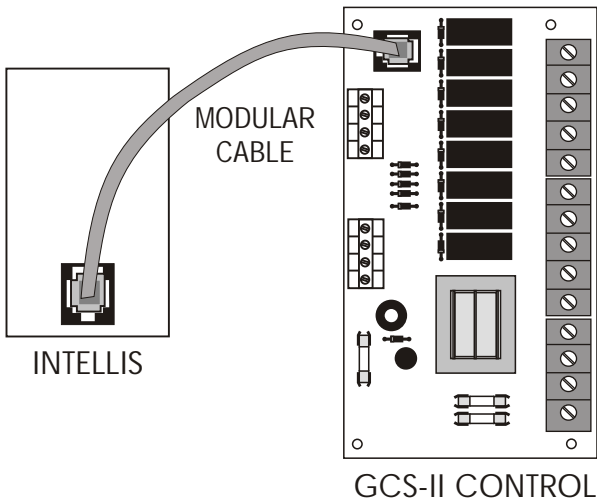

IGC

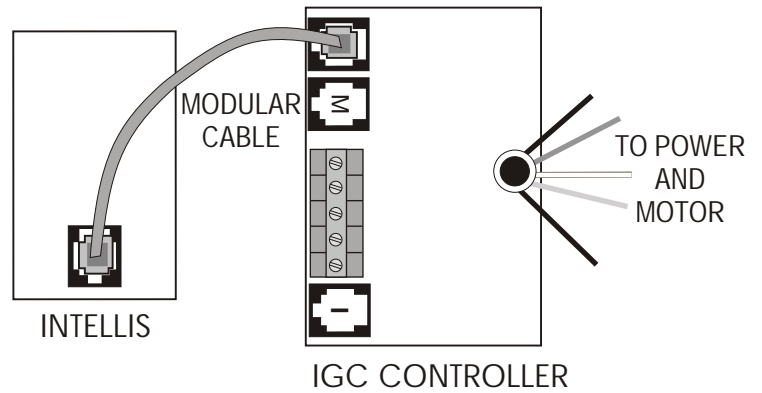

ORDERING INFORMATION

Description	Catalog Number
IntelliS-IGC	6300351 (White), 6300352 (Ivory)
IntelliS-GCS	6300361 (White), 6300362 (Ivory)
IntelliS-AC Single Motor	6300371 (White), 6300373 (Ivory)

INFRARED SWITCH

DESCRIPTION

The Infrared Switch is designed to provide remote access to many of SOMFY's standard controls. By incorporating an addressable infrared sensor into SOMFY's Decorator IGC switch, individual and master control is possible from a single infrared transmitter. The Infrared switch is compatible with the IGC, GCS-II, IGC-HB, IGC II and MCIR. Up to 8 addresses can be assigned in a variety of configurations (i.e. individual window control, room control, floor control, etc.) to meet the requirements of your customers.



MECHANICAL SPECIFICATIONS

Overall Dimensions: L: 4 1/2 in. W: 2 3/4 in. D: 1 1/4 in.

Typical Range in Optimal Conditions: 20 ft.

Installs in a standard single gang electrical box.

OPERATING PROCEDURES

1. Connect from the modular connector on the IR Switch to the modular connector on the IGC, MCIR or GCS. On the IGC, the switch can be connected to either the Master or Individual ports. Refer to instructions for details.
2. Set the unit address using the rotary switch. Position 1 refers to IR address 1, and position F refers to IR address 15. Position 0 is used only for the single channel transmitter.
3. Mount the IR Switch in a single gang box. Ensure nothing obstructs the sensor opening.
4. Operate each motor in one direction using either the push button switch or the infrared transmitter. If the motor does not move in the correct direction, reverse the red and brown wires at the motor. Please refer to IGC, MCIR or GCS instructions for further information.

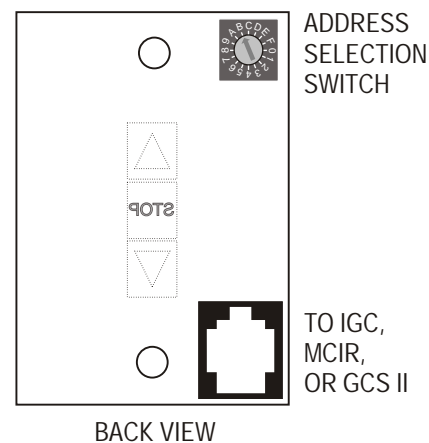

OPTIONS

SINGLE CHANNEL TRANSMITTER: A single motor (address number 0) or group can be operated by pressing either the UP or DOWN buttons on the transmitter. Pressing the center button will stop the motor at its present position.

EIGHT CHANNEL TRANSMITTER: This transmitter has the ability to activate up to 8 motors or groups individually. Press the address of the switch you wish to operate, then the directional command. Pressing a group command (1-4, 5-8, 1-8) and then a direction will activate all switches in the chosen group that are within transmitter range.

1 Channel IR
Transmitter
Cat. No: 6300879



8 Channel IR
Transmitter
Cat. No: 6300988

TYPICAL APPLICATIONS

INDIVIDUAL CONTROL (One Channel)

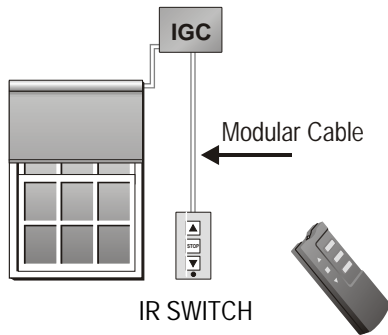

The first illustration shows a single channel transmitter controlling a single motor.

In the second illustration, an eight channel transmitter provides individual and master control. Each switch has a unique address.

Any number of motors can be operated as a group using the IR Switch-GCS version.

INDIVIDUAL AND MASTER CONTROL (Three Channels)

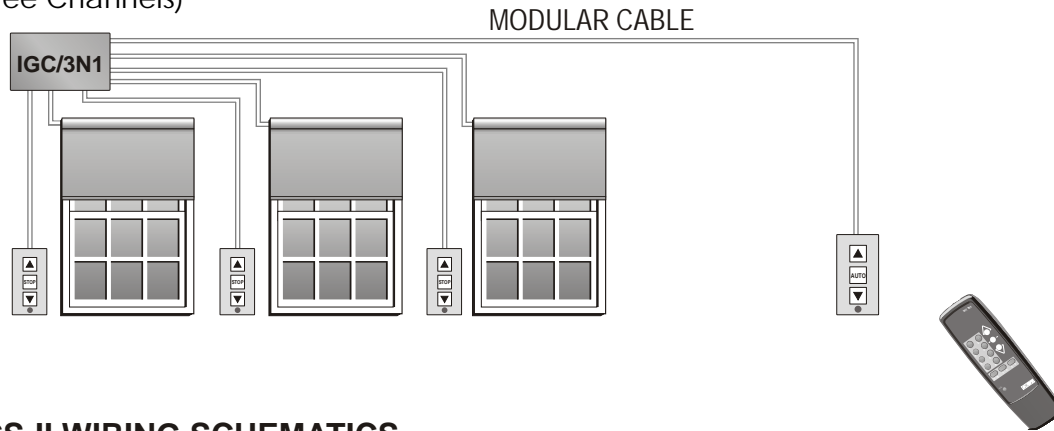

GCS-II WIRING SCHEMATICS

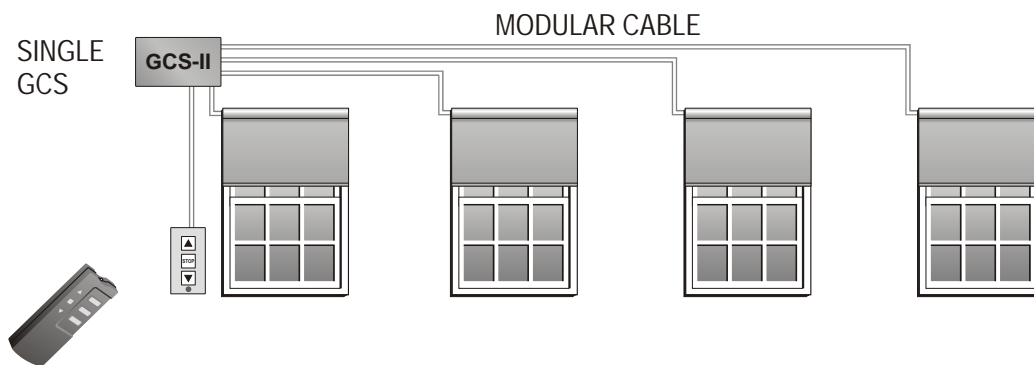

ORDERING INFORMATION

Description

Catalog Number

IR Switch - IGC
IR Switch - GCS

6300050 (White), 6300060 (Ivory)
6300051 (White), 6300061 (Ivory)

Infrared Transmitters
Single Channel Transmitter
Eight Channel Transmitter

6300879
6300988

	<p><i>Individual-Group Control for DC Motors (IGC-DC)</i></p>	<p>22</p>	
	<p><i>DC-5 Control</i></p>	<p>24</p>	
	<p><i>Group Control System II (GCS II)</i></p>	<p>26</p>	
	<p><i>Individual-Group Control (IGC and IGC/3N1)</i></p>	<p>28</p>	
	<p><i>Individual-Group Control II (IGC II and IGC II/3N1)</i></p>	<p>31</p>	
	<p><i>Subgroup Controller</i></p>	<p>34</p>	
	<p><i>Moduline System</i></p>	<p>35</p>	

INDIVIDUAL GROUP CONTROL SYSTEM FOR DC MOTORS (IGC-DC)

DESCRIPTION

The IGC-DC provides control of one or more DC motors in groups and/or individually from one or more locations. It provides both lift and tilt capabilities for horizontal blind applications. The IGC-DC is a very flexible control system that can be configured in a variety of ways (i.e.; individual window control, floor control, total building control, etc.) to meet the requirements of your customers. Unlike the IGC, the IGC-DC is a switch and motor controller all in one package, and can be installed in a single gang electrical box.



MECHANICAL SPECIFICATIONS:

Overall Dimensions: L: 4 1/2 in. W: 2 3/4 in. D: 1 1/8 in.

Installs in a standard single gang electrical box.

ELECTRICAL SPECIFICATIONS

Voltage Rating: INPUT: 12 or 24 VDC

OUTPUT: 12 or 24 VDC 750mA per motor

Approvals: Complies with the National Electrical Code (NEC) Standard

RECOMMENDED TRANSFORMERS

MOTOR TYPE	1 MOTOR	2 MOTOR	3 MOTOR	4 MOTOR	5 MOTOR
LT28A	5700091	5700091	5700091	5700091	5700092
LT28B	5700095	5700093	5700093	5700096	5700096
LV25-B44	5700095	5700093	5700096	5700096	5700096
LV25-B64	5700095	5700093	5700096	5700096	5700096
LW25-B83	5700095	5700093	5700096	5700096	5700098
LT28-H2	5700093	5700098	5700098	5700098	5700098

CONNECTION DIAGRAM

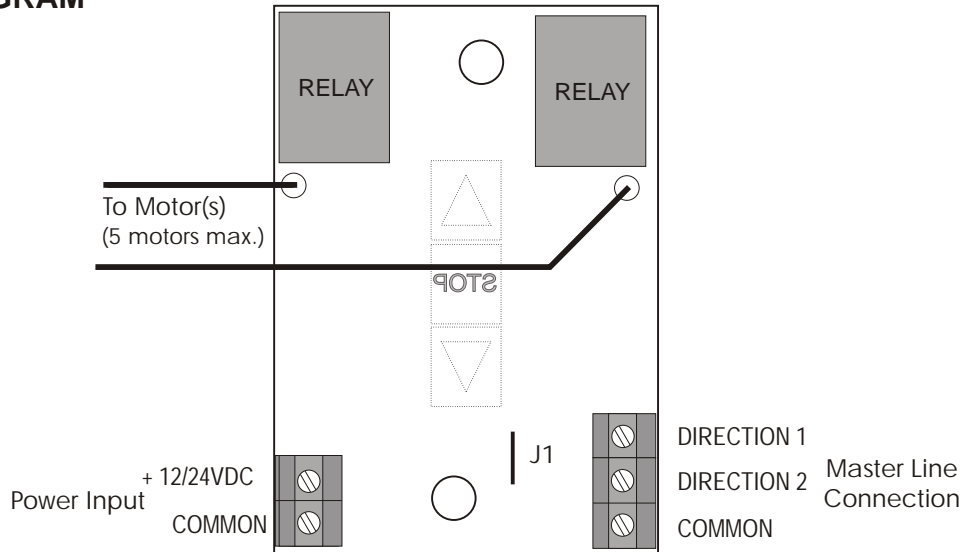

MOTOR CONTROL EXAMPLES

3 DC Motors Individually Controlled

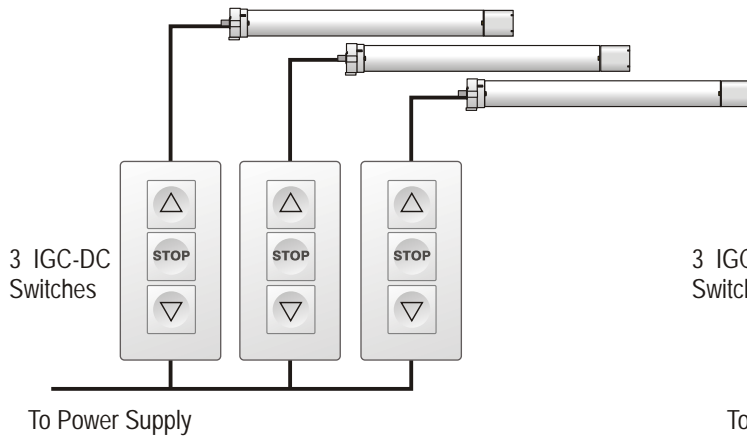

3 DC Motors Controlled Individually & as a Group

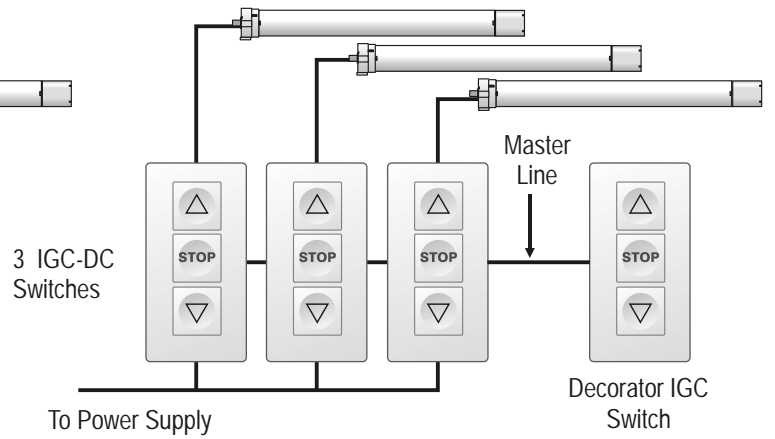

15 DC Motors Controlled as a Group & in Sub-Groups

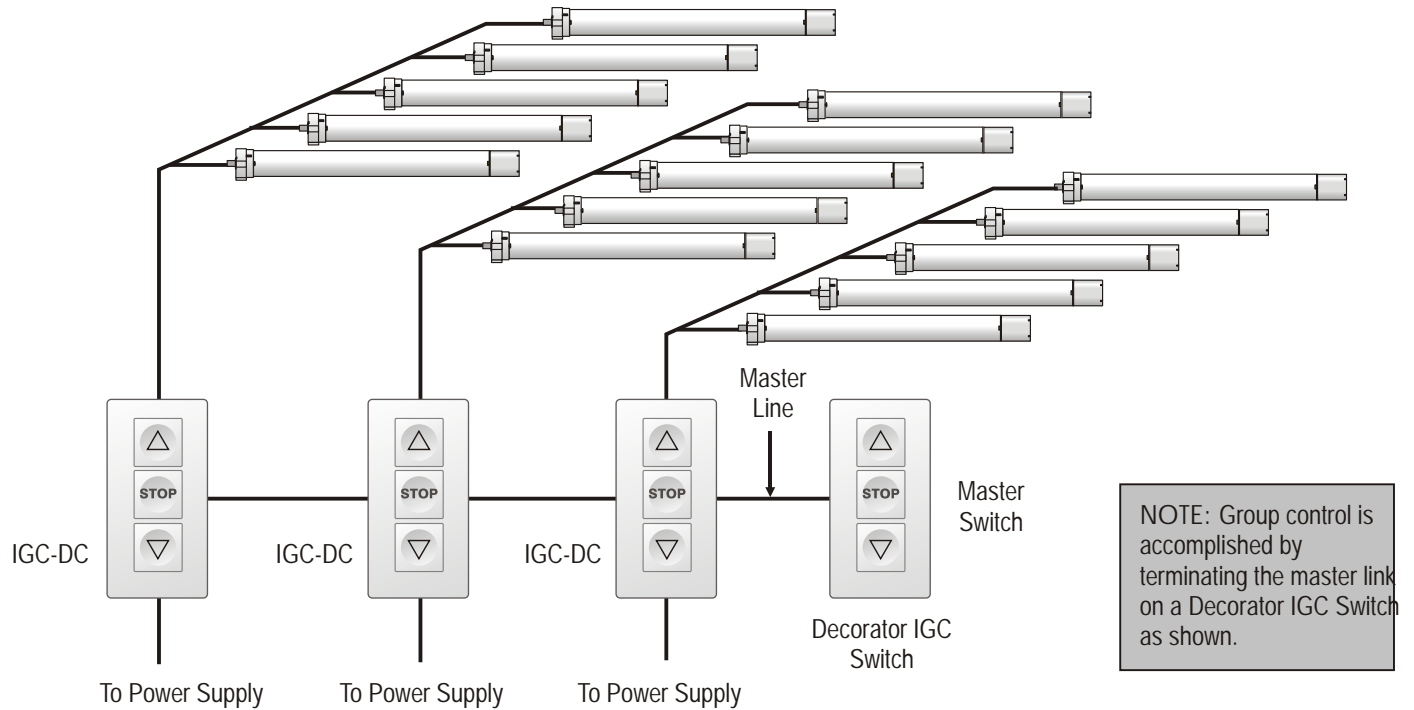

ORDERING INFORMATION

Description	Catalog Number	Description	Catalog Number
Switches		Transformers	
IGC-DC (White)	6300843	12 VDC, 1A	5700088
IGC-DC (Ivory)	6300840	12 VDC, 3A	5700091
Group Switches		12 VDC, 5A	5700092
Single IGC Switch (White)	6300040	24 VDC, 600mA	5700095
Dual IGC Switch (White)	6300041	24 VDC, 1A	5700093
Single IGC Switch (Ivory)	6300140	24 VDC, 2.5A	5700096
Dual IGC Switch (Ivory)	6300141	24 VDC, 6.5A	5700098

DC-5 CONTROL

DESCRIPTION

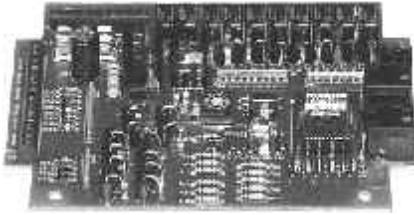

The SOMFY DC-5 is a 5-motor individual and group control system for 12 and 24 volt DC motors. It can be operated by IGC switches, infrared remote, or dry contact inputs. The DC-5 has tilting capabilities for horizontal blind applications, and is available with either 8 channel or 24 channel infrared control.

MECHANICAL SPECIFICATIONS

Overall Dimensions: L: 6 in. W: 4 $\frac{1}{4}$ in. D: 2 $\frac{1}{4}$ in.

Voltage Rating: INPUT: 12 or 24 VDC

OUTPUT: 12 or 24 VDC 750mA per motor

Approvals: Complies with the National Electrical Code (NEC) Standard

ELECTRICAL SPECIFICATIONS

ORDERING INFORMATION

Description	Catalog Number	Description	Catalog Number
DC-5 Control	6300370	Transformers	
DC-5 Control w/ 24 chan IR	6300270	12 VDC, 5A	5700092
Switches		24 VDC, 6.5A	5700098
Single IGC Switch	6300040 (White), 6300140 (Ivory)		
Dual IGC Switch	6300041 (White), 6300141 (Ivory)		
Accessories			
Infrared Sensor	6300866		
Mini IR Sensor	6300022		
Single Channel IR Transmitter	6300879		
Eight Channel IR Transmitter	6300988		
24 Channel IR Transmitter	6300500		
Plastic Enclosure	6111370		

WIRING DIAGRAM

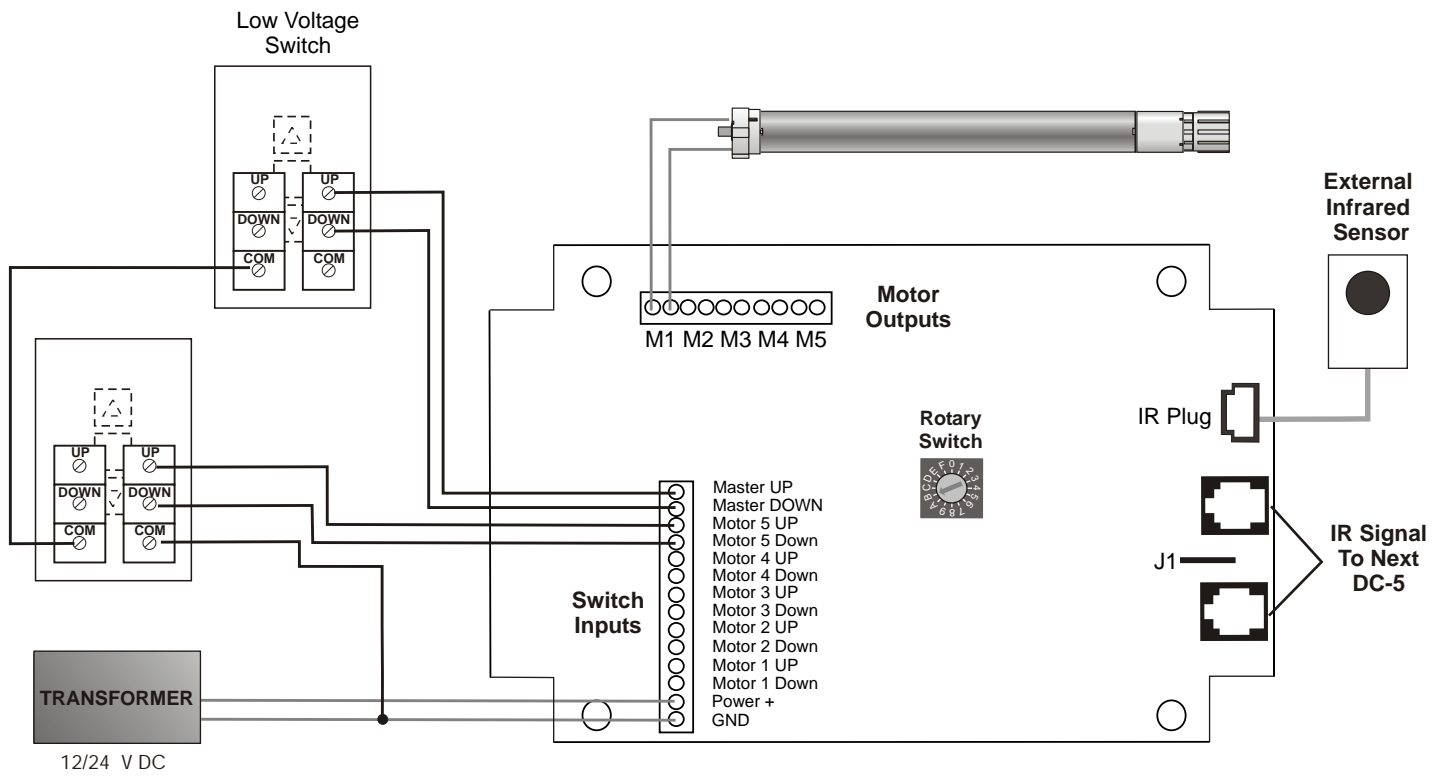

HOME AUTOMATION INTERFACE

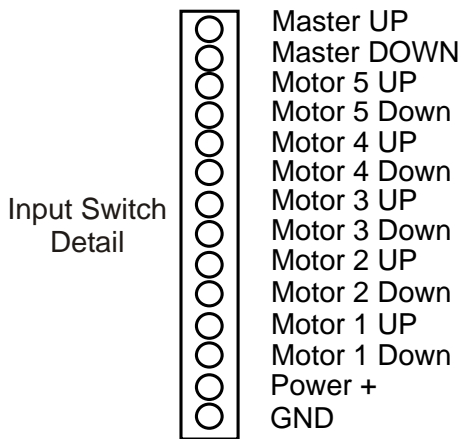

The screw terminals on the DC5 can be used for interfacing to home automation or other third party systems. To activate a Master Up command, a momentary dry contact (relay) closure is required between the MASTER UP input and GND. This contact should remain closed for less than 0.5 seconds to raise or lower a shade, or more than 0.5 seconds to tilt a horizontal blind. Similarly, to activate a Master Down command, a contact closure is required between the MASTER DOWN and GND terminals.

If the window treatment is in motion, a STOP command is given by activating the direction of movement. For example, if the shade is moving up, activating another UP command within 3 minutes will stop the window treatment. Alternately, a contact closure is required between the MASTER UP, MASTER DOWN and GND terminals.

Follow the above timing requirements for each of the individual inputs, Motor 1 through Motor 5.

GROUP CONTROL SYSTEM II

(GCS-II)

DESCRIPTION

The Group Control System-II (GCS-II) permits low voltage control of up to four SOMFY operators with one or more switches, from one or more locations. Optional low voltage control can be accomplished using SOMFY's Decorator Somfy-Matic™, Decorator Comfort Control or Radio Remote Control Kit. The GCS-II offers only group control, and does not have the capability of operating each motor individually. The Group Control System-II is UL and cUL approved.

For applications requiring more than 4 motors operated by the same switch, the GCS-II can be daisy-chained by way of the low voltage switch terminals.



MECHANICAL SPECIFICATIONS

Overall Dimensions: L: 8 in. W: 10 in. D: 4 in.

ELECTRICAL SPECIFICATIONS

Voltage Ratings:

INPUT: Line Voltage: 115 VAC +/- 10% 50/60 Hz 20A
 Low Voltage: 12 VDC 0.3A

OUTPUT: 115 VAC 5A (Each motor)
 Fuses: (Motor) 2 x 10A (One per two motors)
 (Low Voltage) 1/2A

Approvals:

Conforms to UL508 standard for industrial controls
 Complies with the National Electrical Code Standards (NEC)

HOME AUTOMATION INTERFACE

MODULAR CONNECTOR



SENSORS CONNECTION

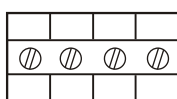

12 VDC
 WIND
 SENSORS

LOW VOLTAGE SWITCH CONNECTION

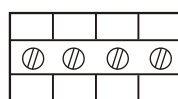

UP
 DOWN
 COMMON

Low voltage terminals are provided on the GCS-II for interfacing to home automation or other third party systems. To activate an Up command, a maintained dry contact (relay) closure is required between the UP input and COMMON. This contact should remain closed for approximately 3 minutes to ensure full travel of the window treatment. Similarly, to activate a Down command, a contact closure is required between the DOWN and COMMON terminals. The window treatment will stop when the contact closure is released.

TYPICAL APPLICATION



GCS-II WIRING DIAGRAM

CAUTION: Before proceeding with the line voltage wiring instructions, the up and down limits of each motor should be set using the SOMFY tester cable (Cat. No. 6020086). Refer to the limit switch instructions packaged with each SOMFY motor for more information.

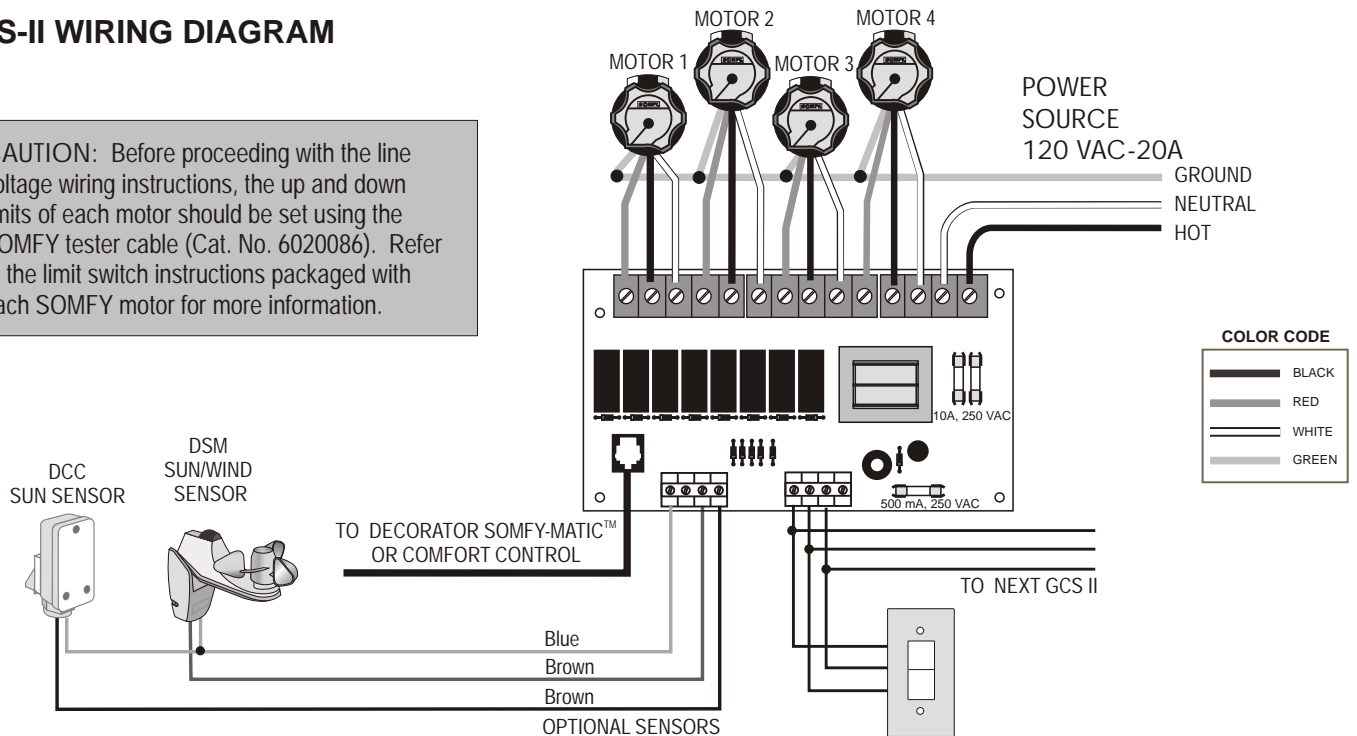

*When using DCC, remove wind connection on GCS-II

ORDERING INFORMATION

Description	Catalog Number	Description	Catalog Number
GCS-II 115 VAC	6300123	Maintained Paddle Switch (Ivory)	6120726
GCS-II 220 VAC	6300124	Maintained Paddle Switch (White)	6120727
Infrared Switch	6300051 (White),	Momentary Paddle Switch (Ivory)	6120734
6300061 (Ivory)		Momentary Paddle Switch (White)	6120735
IntelliS Timer	6300361 (White), 6300362 (Ivory)	Maintained Toggle Switch (Ivory)	6120745
Remote Control Kit	6300696	Maintained Toggle Switch (White)	6120746
Maintained Rocker Switch	6120144	Momentary Toggle Switch (Ivory)	6120747
Momentary Rocker Switch	6120155	Momentary Toggle Switch (White)	6120748

INDIVIDUAL-GROUP CONTROL

(IGC and IGC/3N1)

DESCRIPTION

The IGC series provides control of one or more motors in groups and/or individually from one or more locations. This advanced yet simple to install modular control system can be activated manually or automatically. The heart of the system is the IGC Motor Controller used for each motor. However, greater economy can be obtained using the IGC/3N1 version for those jobs that call for controlling at least three motors individually or in groups.

The IGC is a very flexible control system that can be configured in a variety of ways (individual window control, floor control, total building control, etc.) to meet the requirements of your customers.

The Individual IGC Controller has an added feature. It is equipped with a dry contact input that can interface with a window alarm system. One typical application is for casement windows; when the window is open, the motor will not operate. This will help prevent damage to window coverings.

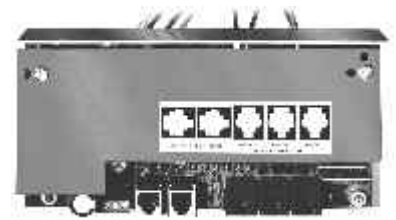

MECHANICAL SPECIFICATIONS

Overall Dimensions: IGC: L: 3 1/2 in. W: 3 3/8 in. D: 2 1/4 in.

IGC/3N1: L: 7 3/16 in. W: 3 1/2 in. D: 1 7/8 in.

IGC fits in a 2 gang masonry electrical box. IGC/3N1 fits in a 4 gang masonry electrical box.

ELECTRICAL SPECIFICATIONS

Voltage Ratings:

IGC: INPUT:
Line Voltage: 115 VAC +/- 10% 50/60 Hz
Low Voltage: 12 VDC 90mA maximum consumption

OUTPUT:
115 VAC 5A 1/4 HP
Fuse 5A

IGC/3N1: INPUT:
Line Voltage: 115 VAC +/- 10% 50/60 Hz
Low Voltage: 12 VDC 185mA maximum consumption

OUTPUT:
115 VAC 15A (5A per motor) 1/4 HP
Fuse: 3 x 5A

Approvals:

Both the IGC and IGC/3N1 conform to UL508 for industrial controls.
Complies with the National Electrical Code Standards (NEC)
UL and cUL approved

APPLICATION NOTES

The Individual-Group Control System is compatible with other SOMFY Controls (i.e., Remote Control, IntelliS Timer, Decorator Somfy-Matic™, Decorator Comfort Control, etc.) and other security, lighting and HVAC systems.

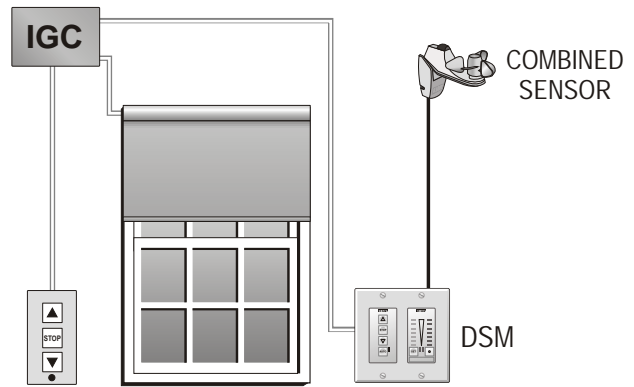

IGC WIRING SCHEMATIC

M = MASTER
IND = INDIVIDUAL

CAUTION: Before proceeding with the line voltage wiring instructions, the up and down limits of each motor should be set using the SOMFY tester cable (Cat. No. 6020086). Refer to the limit switch instructions packaged with each SOMFY motor for more information.

COLOR CODE

	BLACK
	BROWN
	RED
	WHITE
	GREEN

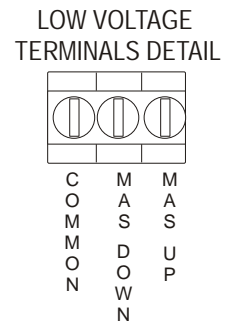
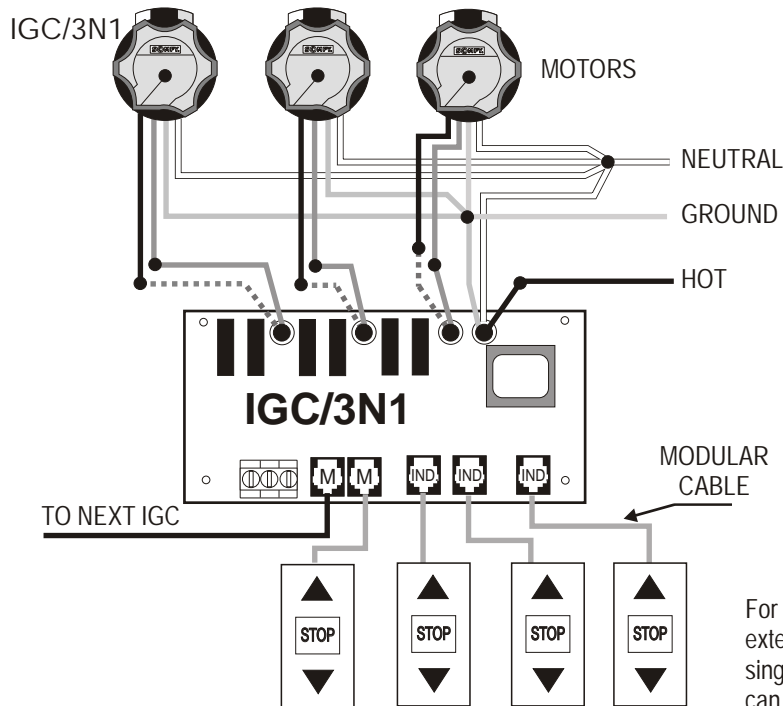

For group only control from an external device, a single-pole, single-throw momentary switch can be connected between either the MAS (Master) UP and COMMON or MAS DOWN and COMMON terminals.

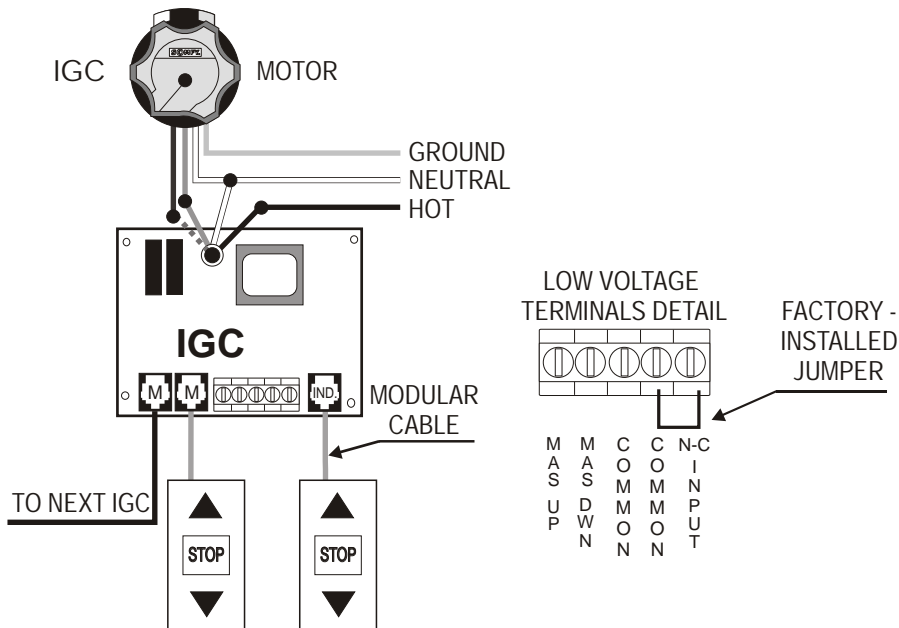

For group only control from an external device, a single-pole, single-throw momentary switch can be connected between either the MAS UP and COMMON or MAS DOWN and COMMON terminals.

The N-C (normally closed) INPUT terminal is for a normally closed contact connected to a casement window or french door. When the door or window opens, this contact opens and disables the down direction. **DO NOT REMOVE FACTORY INSTALLED JUMPER IF THIS FEATURE IS NOT UTILIZED.**

HOME AUTOMATION INTERFACE

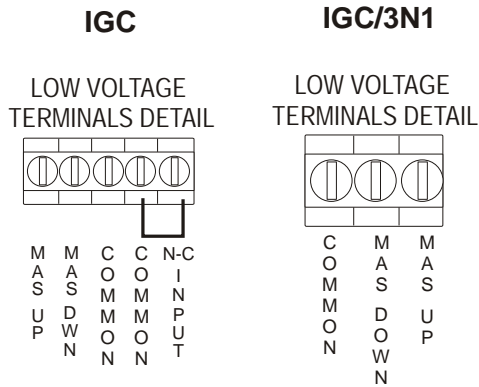

Low voltage terminals are provided on both the single motor IGC and IGC/3N1 for interfacing to home automation or other third party systems. To activate a Master Up command, a momentary dry contact (relay) closure is required between the MAS UP input and COMMON. This contact should remain closed at least 0.5 seconds, but no more than 1 second. Similarly, to activate a Master Down command, a contact closure is required between the MAS DWN and COMMON terminals.

If the window treatment is in motion, a Stop command is given by activating the direction of movement. For example, if the treatment is moving up, activating another UP command within 3 minutes will stop the window treatment. Alternately, to activate a STOP command, a contact closure is required between the MAS UP, MAS DWN and COMMON terminals.

IGC - HB FOR HORIZONTAL BLINDS

The IGC-HB and IGC-HB/3N1 are specifically designed to provide lift and tilt capability for horizontal blind applications. They are completely compatible with SOMFY's standard IGC, so wiring and basic operation are similar. When using the IGC-HB in combination with a decorator IGC switch, a blind can be raised or lowered by momentarily pressing and releasing the UP or DOWN button. The TILT function is activated by pressing and holding the button corresponding to the desired direction of tilt. When the slats are at the desired angle, simply release the directional button.

For Home Automation interfacing, a contact closure is required as with the standard IGC. The contact should remain closed for less than 0.5 seconds for raising or lowering blinds and greater than 0.5 seconds for tilting. The Stop function can only be activated with a simultaneous contact closure between the MAS UP, MAS DWN and COMMON terminals.

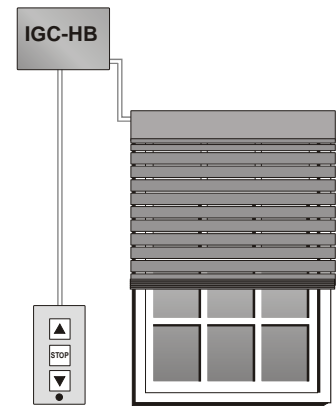

ORDERING INFORMATION

Description	Catalog Number	
IGC - 115 VAC	6300717	
IGC - HB	6300030	
IGC - 220 VAC	6300845	
IGC - Dry Contact Capability	6300713	
IGC/3N1 - 115 VAC	6300719	
IGC-HB/3N1	6300035	
IGC/3N1 - 220 VAC	6300846	
Switches		
Single IGC Switch	6300908 (White)	6300937 (Ivory)
Dual IGC Switch	6300909 (White)	6300938 (Ivory)
Infrared Switch	6300050 (White)	6300060 (Ivory)
Options		
IGC Sub Group	6300715	
RTS Receiver	6300450	
IntelliS Timer	6300351 (White)	6300352 (Ivory)
Outdoor Digital Keypad	6300849	
2 Gang Masonry Electrical Box	5670323	
4 Gang Masonry Electrical Box	5670064	

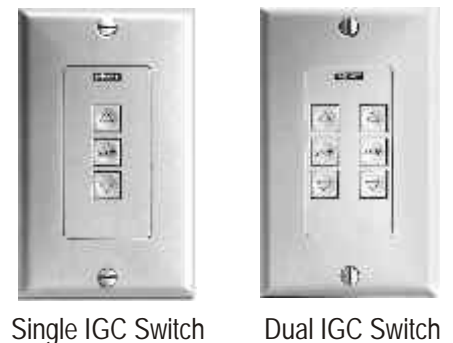

NOTE: See accessories section for modular cable and connectors

INDIVIDUAL-GROUP CONTROL II

(IGC II and IGC II/3N1 - X10 COMPATIBLE)

DESCRIPTION

The IGC-II system provides control of one or more motors in groups and/or individually from one or more locations. This advanced, yet simple-to-install modular control system can be activated manually or automatically. The heart of the system is the IGC-II Motor Controller used for each motor. However, greater economy can be obtained using the IGC-II/3N1 for those jobs that call for controlling three motors individually or in groups. The IGC-II is a very flexible control system that can be configured in a variety of ways (i.e., individual window control, floor control, total building control, etc.) to meet the requirements of your customers.



The IGC-II and IGC-II/3N1 controllers are also compatible with X10 power line transmission technology. When the IGC-II is used with the SOMFY X10 system, it is possible (without additional wiring) to control motorized coverings as well as other X10 compatible devices.

MECHANICAL SPECIFICATIONS

Overall Dimensions: IGC-II: L: 6 in. W: 8 in. D: 4 in.

IGC-II/3N1: L: 6 in. W: 10 in. D: 4 in.

ELECTRICAL SPECIFICATIONS

Voltage Ratings:

IGC-II:	INPUT:			
	Line Voltage:	115 VAC	+/- 10%	50/60 Hz
	Low Voltage:	12 VDC	90mA maximum consumption	
	OUTPUT:	115 VAC	5A	1/4HP
		Fuse	5A	
IGC-II/3N1	INPUT:			
	Line Voltage:	115 VAC	+/- 10%	50/60 Hz
	Low Voltage:	12 VDC	185mA maximum consumption	
	OUTPUT:	115 VAC	15A (5A per motor)	
		Fuse	3 X 5A	

Approvals:

Both the IGC-II and IGC-II/3N1 conform to UL508 standard for industrial controls. Complies with the National Electrical Code Standards (NEC).

WIRING SCHEMATIC

M = MASTER
IND = INDIVIDUAL

CAUTION: Before proceeding with the line voltage wiring instructions, the up and down limits of each motor should be set using the SOMFY tester cable (Cat. No. 6020086). Refer to the limit switch instructions packaged with each SOMFY motor for more information.

COLOR CODE

	BLACK
	RED
	WHITE
	GREEN

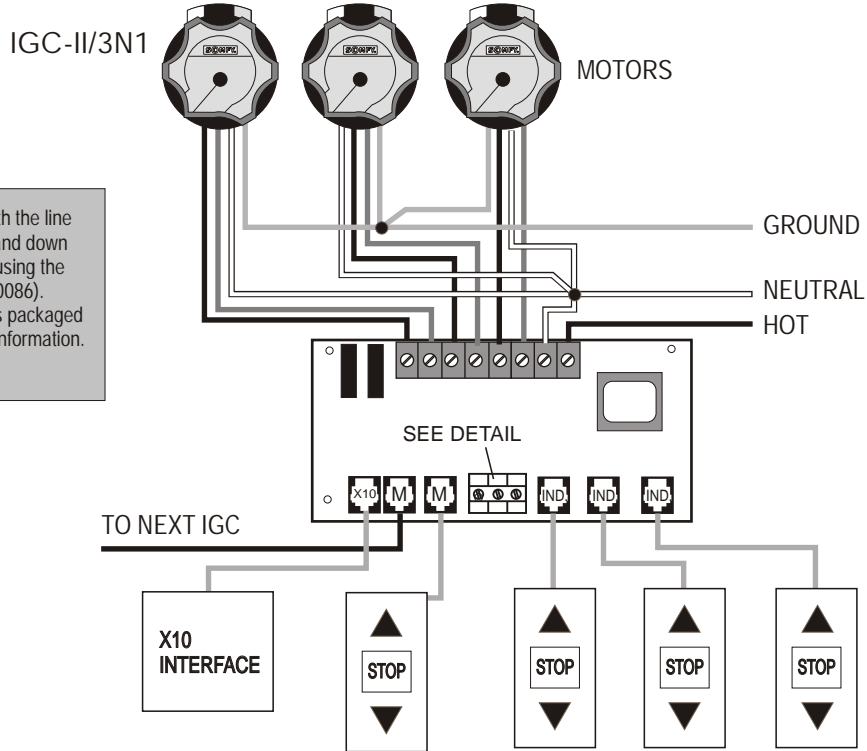

LOW VOLTAGE TERMINALS DETAIL

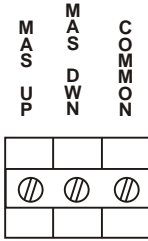

For group only control from an external device, a single-pole, single-throw momentary switch can be connected between either the MAS UP and COMMON or MAS DOWN and COMMON terminals.

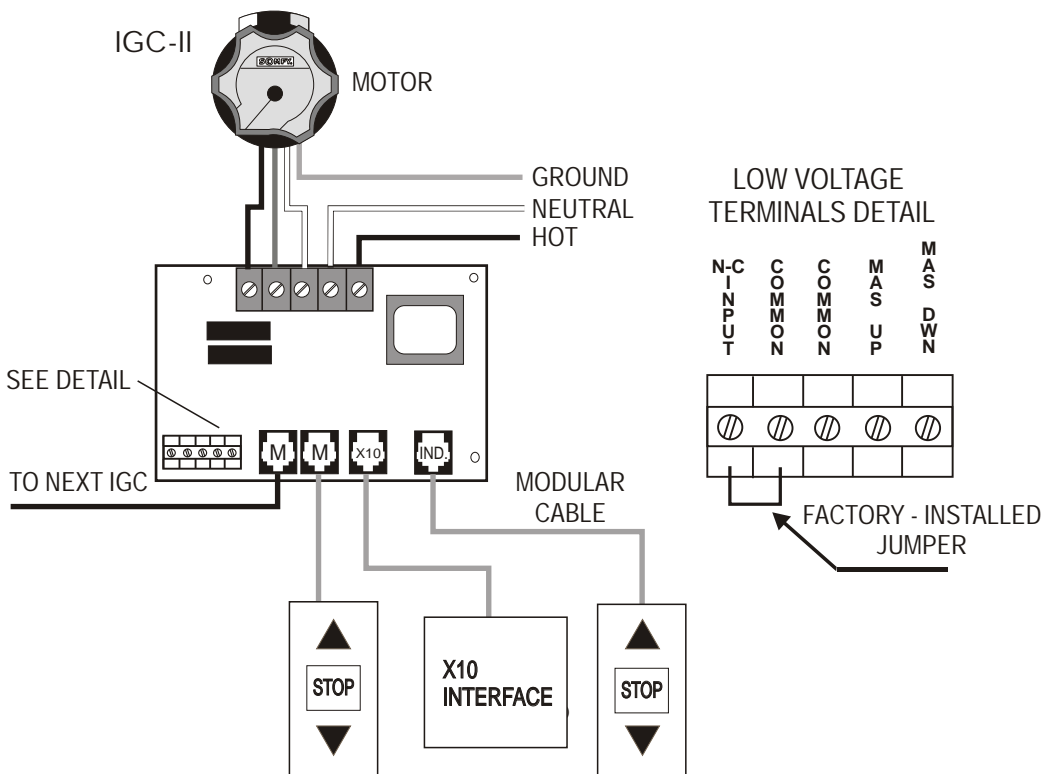

LOW VOLTAGE TERMINALS DETAIL

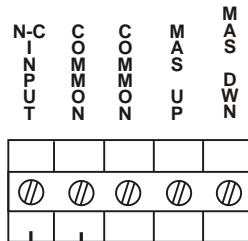

For group only control, a single-pole, single-throw momentary switch can be connected between either the MAS (Master) UP and COMMON or MAS DOWN and COMMON terminals.

The N-C (normally closed) INPUT terminal is for a normally closed contact connected to a casement window or french door. When the door or window opens, this contact opens and disables the down direction. **DO NOT REMOVE FACTORY INSTALLED JUMPER IF THIS FEATURE IS NOT UTILIZED.**

APPLICATION NOTES

The Individual-Group Control System II is compatible with other SOMFY Controls (i.e., Remote Control, IntelliS Timer, Decorator Somfy-Matic™, Decorator Comfort Control, etc.) and other security, lighting and HVAC systems. The individual IGC-II Controller has an added feature. It is equipped with a dry contact input that can interface with a window alarm system. One typical application is for casement windows; when the window is open, the motor will not operate. This is to help prevent damage to window coverings.

IGC-II/3N1 Three Motor Control with Individual and Master Control

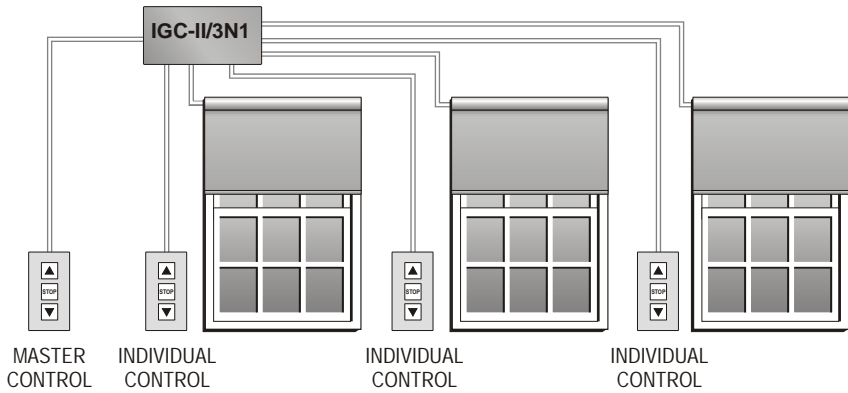

IGC-II Single Motor Control with Command Center

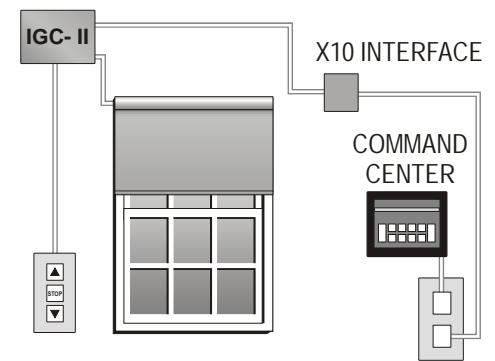

HOME AUTOMATION INTERFACE

IGC-II

LOW VOLTAGE
TERMINALS DETAIL

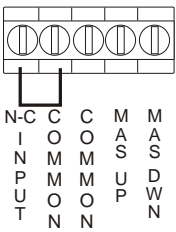

IGC-II/3N1

LOW VOLTAGE
TERMINALS DETAIL

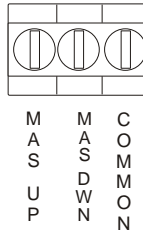

Low voltage terminals are provided on both the single motor IGC-II and IGC-II/3N1 for interfacing to home automation or other third party systems. To activate a Master Up command, a momentary dry contact (relay) closure is required between the MAS UP input and COMMON. This contact should remain closed at least 0.5 seconds, but no more than 1 second. Similarly, to activate a Master Down command, a contact closure is required between the MAS DWN and COMMON terminals. To activate a STOP command, a contact closure is required between the MAS UP, MAS DWN and COMMON terminals.

ORDERING INFORMATION

Description	Catalog Number	Description	Catalog
IGC-II	6300817	Switches	
IGC-II/3N1	6300819	Single IGC Switch	6300908 (White) 6300937 (Ivory)
		Dual IGC Switch	6300909 (White) 6300938 (Ivory)
		Infrared Switch	6300050 (White) 6300060 (Ivory)
X10 Components		Options	
IRC Command Center	6150463	IGC Sub Group	6300715
X10 Interface	6300821	RTS Receiver	6300450
IRC1000 Transmitter	6150460	Outdoor Digital Keypad	6300849
		IntelliS Timer	6300351 (White) 6300352 (Ivory)

IGC SUB-GROUP CONTROL

DESCRIPTION

The SubGroup controller is designed for use with Somfy's IGC or IGC-II controls. It allows for master or group control of a number of IGC controls from a single switch while still maintaining independent operation of each control or group.

- Mounts in single gang box
- Sub-groups operate independently
- Master line activates all sub-groups
- Only one level of sub-grouping is possible
Do not connect a sub-group port of one sub-group control to a master port of another sub-group control. If multi-level sub-grouping is needed, it must be done at the IGC controls.



Cat. No. 6300715

TYPICAL APPLICATION

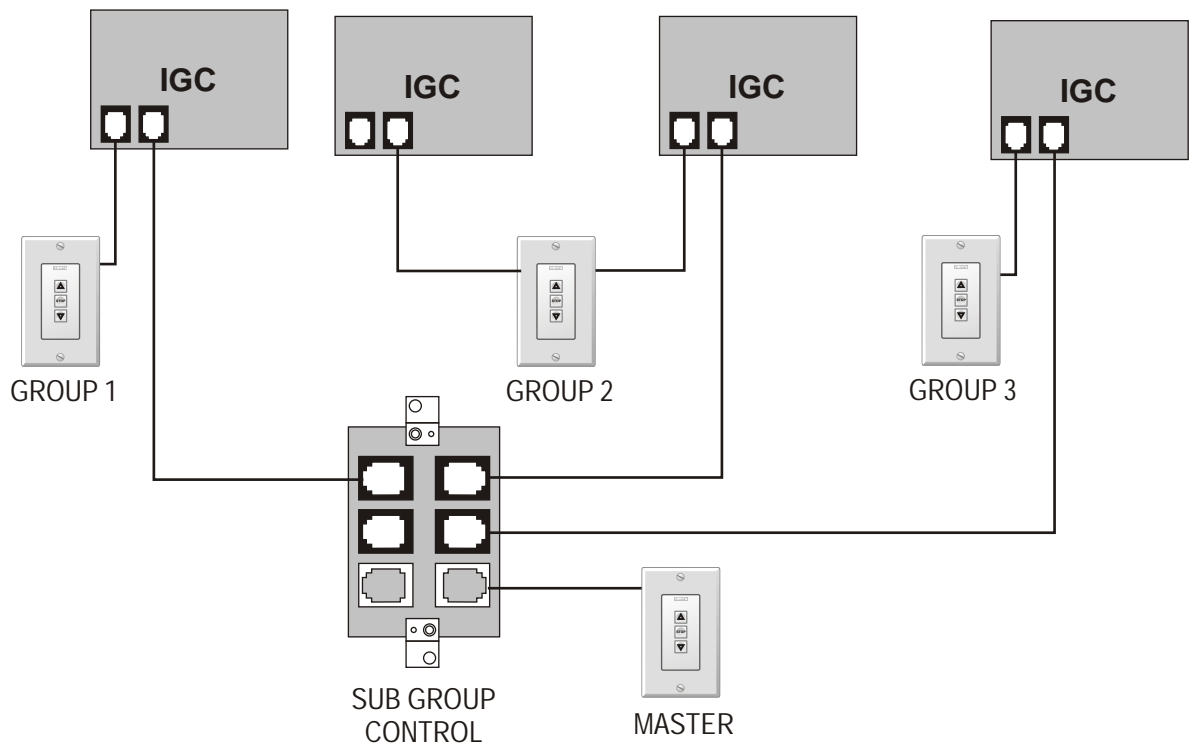

MODULINE SYSTEM

DESCRIPTION

The Moduline system features individual and group controls built into standard DIN casings which are attached to DIN rails in a cabinet. The system includes modules for individual, group and master control.

A preassembled control system of Moduline components can be built to meet your specifications. The Moduline system requires minimal wiring and reduced troubleshooting and maintenance times. It offers an integrated and organized means for controlling SOMFY motors.



SYSTEM COMPONENTS

Supply/General Control MODULINE 9000

The Moduline 9000 supplies power and master control for up to 15 individual controls that are connected to its right side.

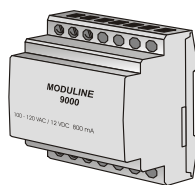

Sub Group Control MODULINE 10000

The Moduline 10000 allows group operation of a number of Individual controls from a single switch. This module will control any Moduline connected on its right side.

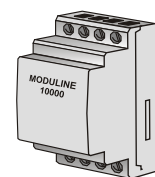

Individual Control MODULINE 8000

This device provides individual control of a window treatment. It communicates with other modules, such as the 9000, that are connected in line with it.

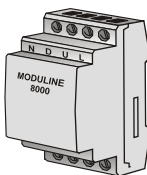

Sun and Wind Interface MODULINE 1010

This module interfaces with a Sun and Wind Sensor to provide shading from the sun and protection from the wind automatically.

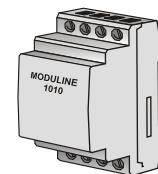

Individual Control for Horizontal Blinds MODULINE 8100

This module provides individual control of a horizontal blind. It is specifically designed to provide both lift and tilt capabilities.

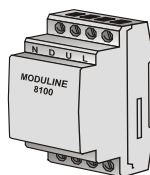

SPECIFICATIONS

MODULINE 9000

Electrical Specifications: INPUT: 120 VAC 50/60 Hz OUTPUT: 12VDC, 0.5A (to bus line)

Mechanical Specifications: L: 2 ⁴/₅ in. W: 3 ²/₅ in. D: 2 ¹/₂ in.

MODULINE 8000 & 8100

Electrical Specifications: INPUT: 12 VDC (from Moduline 9000); OUTPUT: 120 VAC 5A

Mechanical Specifications: L: 1 ²/₅ in. W: 3 ²/₅ in. D: 2 ¹/₂ in.

MODULINE 10000

Electrical Specifications: INPUT: 12 VDC (from Moduline 9000)

Mechanical Specifications: L: 1 ²/₅ in. W: 3 ²/₅ in. H: 2 ¹/₂ in.

MODULINE 1010

Mechanical Specifications: L: 1 ²/₅ in. W: 3 ²/₅ in. H: 2 ¹/₂ in.

TYPICAL MODULINE WIRING DIAGRAM

CAUTION: Before continuing with the line voltage wiring instructions, the up and down limits of each motor should be set using the SOMFY tester cable (Cat. No. 6020086). Refer to limit switch instructions packaged with each SOMFY motor for more information.

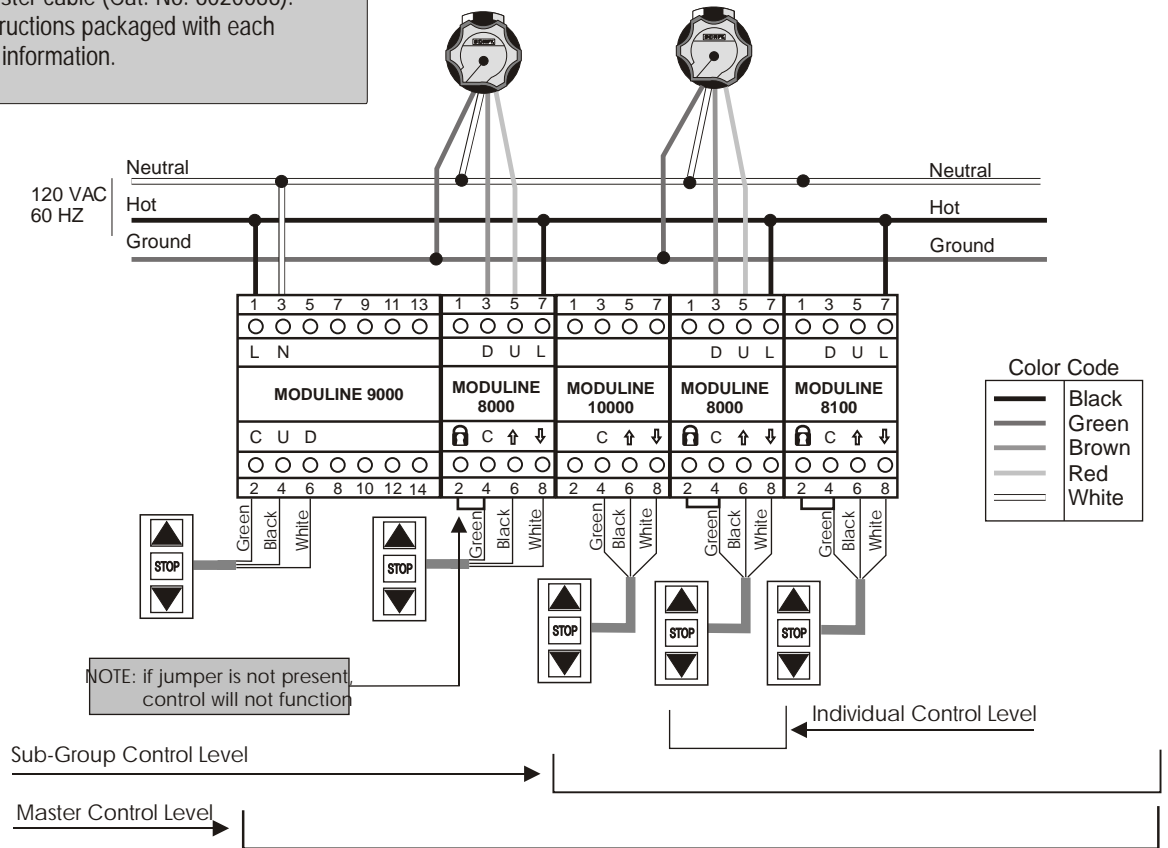

OPERATING PROCEDURES

A. Individual Motor Operation

A single motor can be controlled by a Moduline 8000 from its corresponding switch. To activate either direction, momentarily depress the button corresponding to the desired direction. A single motor can be stopped in any position by depressing the stop button.

B. Subgroup Operation

A group of motors can be controlled by connecting Moduline 8000s to the right of a Moduline 10000. When the switch connected to the Moduline 10000 is depressed, all Moduline

8000s in the subgroup (up to the next Moduline 10000) will be activated.

C. Master Control

All the motors (Up to 15 Moduline 8000s) in a system can be controlled and operated by a single switch connected to a Moduline 9000. To activate any direction, momentarily depress the corresponding button. The motors can be stopped in any position by depressing the stop button.

ORDERING INFORMATION

Description	Catalog Number	Description	Catalog Number
Moduline 8000	6150472	Single IGC Switch	6300040 (White), 6300140 (Ivory)
Moduline 8100	6150476	Dual IGC Switch	6300041 (White), 6300141 (Ivory)
Moduline 9000	6150474	Linking Module	6150473
Moduline 10000	6150471		
Moduline 1010	6150478		

NOTE: Moduline components can be assembled as a UL listed system by SOMFY. Please consult your sales representative for details.

	<p><i>Decorator Somfy-Matic (DSM)</i></p>	<p>38</p>	
	<p><i>Decorator Comfort Control (DCC)</i></p>	<p>40</p>	
	<p><i>Eolis Wind Control</i></p>	<p>42</p>	
	<p><i>Eolis Receiver (Wind-Remote Control)</i></p>	<p>43</p>	
	<p><i>Soliris Receiver Telis Soliris Transmitter</i></p>	<p>45</p>	
	<p><i>RTS Sensors</i></p>	<p>48</p>	

DECORATOR SOMFY-MATIC™ (DSM)

DESCRIPTION

The Decorator Somfy-Matic™ (DSM) enables a retractable awning to provide shading from the sun and protection from the wind automatically and conveniently. The DSM combined sun and wind sensor continually monitors sun intensity and wind speed, triggering the control unit to extend or retract the awning as needed.

The Decorator Somfy-Matic™ features advanced circuitry that assures factory preset accuracy and proven reliability. It aids in protecting furniture and carpeting from fading and saves on heating and air conditioning costs. With its sleek design, the DSM will complement any home decor. Combine this with the capability of being linked to SOMFY'S Group Control and IGC systems, and you've got the most flexible product on the market today!

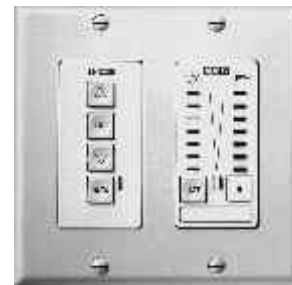

MECHANICAL SPECIFICATIONS

Overall Dimensions: L: 3 1/2 in. W: 2 3/4 in. D: 1 1/3 in.
Operating temperature range: -20 °C to 50 °C (-5 °F to 120 °F)
Wind Speed: From 12 to 31 mph
Fits in most 2 gang electrical boxes

ELECTRICAL SPECIFICATIONS

Voltage Rating:
Single Motor: INPUT: 115 VAC +/- 10% 50/60Hz
OUTPUT: 115 VAC 1/4 HP 5A

IGC/GCS II: INPUT: 12-15 VDC 150 mA (Supplied by IGC or GCS II)
OUTPUT: 12-15 VDC 100 mA Open Collector

Approvals:

The DSM Single Motor Control is approved per UL508 for industrial controls (UL, cUL);
Conforms to the National Electrical Code Standards (NEC)

INSTALLATION PROCEDURES

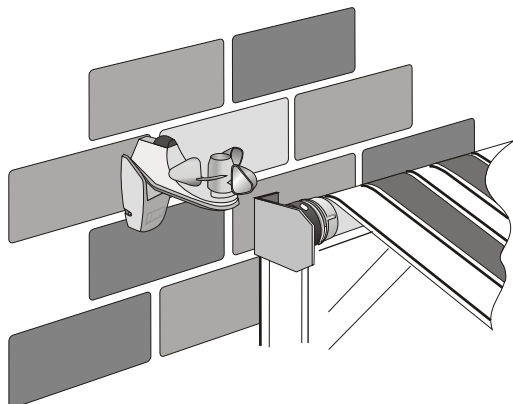

1. With power off, connect high and low voltage wires according to the wiring diagram. Test the wiring by pressing the DOWN button on the control. If the awning does not extend, or the screen does not lower, turn off power and reverse the red and black wires at the motor. FAILURE TO CORRECT THIS ERROR WILL CAUSE SERIOUS DAMAGE TO THE MOTOR OR AWNING BY EXTENDING IT DURING WINDY CONDITIONS.
2. The combined sensor should be placed close to the awning or shading system to make sure the wind speed and sun light is measured at the product. Guard against installing the sensor too close to an obstruction such as a chimney, gutter or under the awning itself. It should also not be mounted in the shade or be obstructed by trees. It may be necessary to reposition the sensor to get the best possible sun and wind readings. The sensor should not be more than 100 feet from the control. Remove the back cover of the sensor and connect the three wire cable (included) from the terminals on the sensor to the terminals on the control.

OPERATING PROCEDURES

- Pressing the UP button will move the awning in, while the DOWN button will extend the awning when pressed. If a motor does not move in the correct direction, turn off the circuit breaker(s) and reverse the red and black wires at the corresponding motor(s). FAILURE TO CORRECT THIS ERROR WILL CAUSE AWNING TO EXTEND DURING WINDY CONDITIONS AND MAY CAUSE SERIOUS DAMAGE.
- Pressing the STOP button will stop the motor(s) in its present position.
- When the monitored sun intensity is greater than the DSM setting, the DOWN direction will activate after 3.5 minutes. The sun LED will remain on for as long as this condition exists. If the sun intensity is less than the DSM setting, the UP direction will activate after 12 minutes (if the auto LED is illuminated). The sun LED will blink during this period.
- When the monitored wind speed is greater than the DSM setting, the UP direction will activate after 2 seconds. The wind LED will remain on as long as this condition exists. When the wind speed drops below the set value, the DSM will return to normal mode after 15 minutes. The wind LED will blink and the motors are prevented from operating during this period.
- When the AUTO button is pressed, the AUTO LED will turn on or off depending on its previous status. Manual mode is designated by the LED being off. If the DSM is in manual mode, the sun level has no influence on motor control. The wind speed is constantly monitored and acted on regardless of AUTO setting. Manual operation will override automatic control for one full cycle. To reset, press the auto button OFF and ON.

DSM WIRING DIAGRAM

CAUTION: Before continuing with the line voltage wiring instructions, the up and down limits of each motor should be set using the SOMFY tester cable (Cat. No. 6020086). Refer to limit switch instructions packaged with each SOMFY motor for more information.

NOTE: When using a GCS II, the sun and wind sensors can be connected to the GCS II instead of the DSM if convenient.

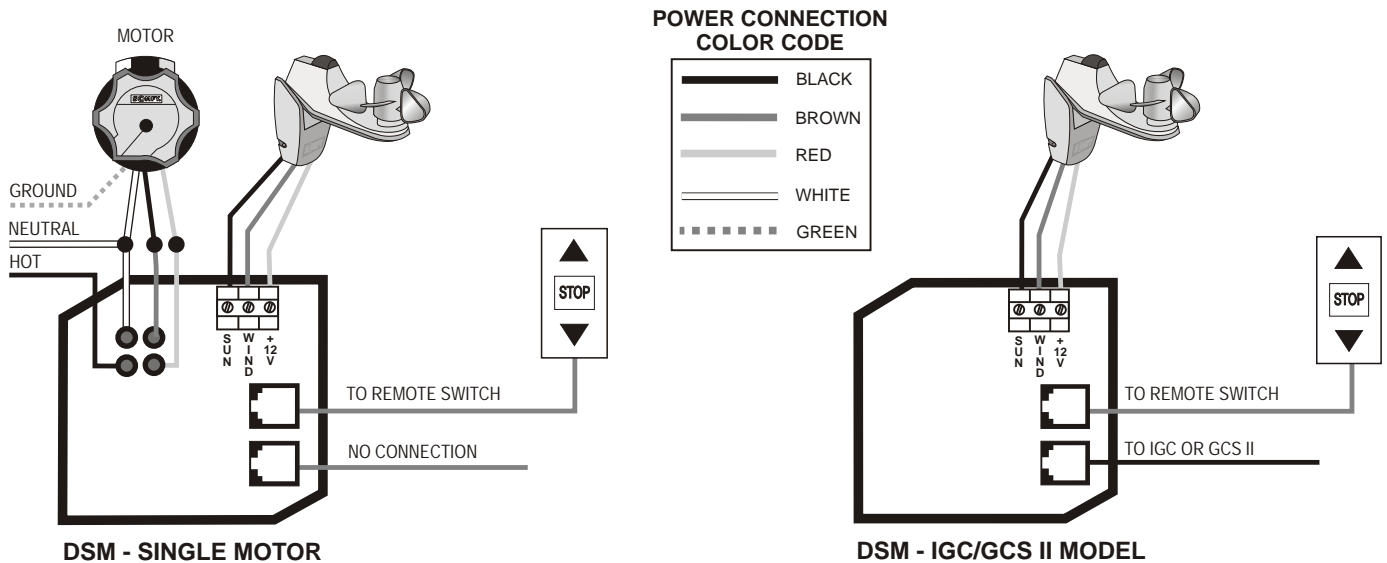

ORDERING INFORMATION

Description	Catalog Number
DSM - Single Motor	6300899 (White) 6300929 (Ivory)
DSM - IGC	6300895 (White) 6300925 (Ivory)
DSM - GCS II	6300903 (White) 6300933 (Ivory)

OPTIONS

Combined Sensor	6150545
Optional Switch	6300908 (White) 6300937 (Ivory)
RTS Radio Receiver	6300450